

OVERLAPPING BLADES

BXS5 Secondary Belt Cleaner

Secondary belt cleaners are typically installed immediately after the belt leaves contact with the drive pulley. Individual blades adapt to worn belts and allow belt clips to pass through.

These high-efficiency blades have superior wear-resistance and maintain blade-to-belt contact. Double tensioning equipment gives better pressure distribution.

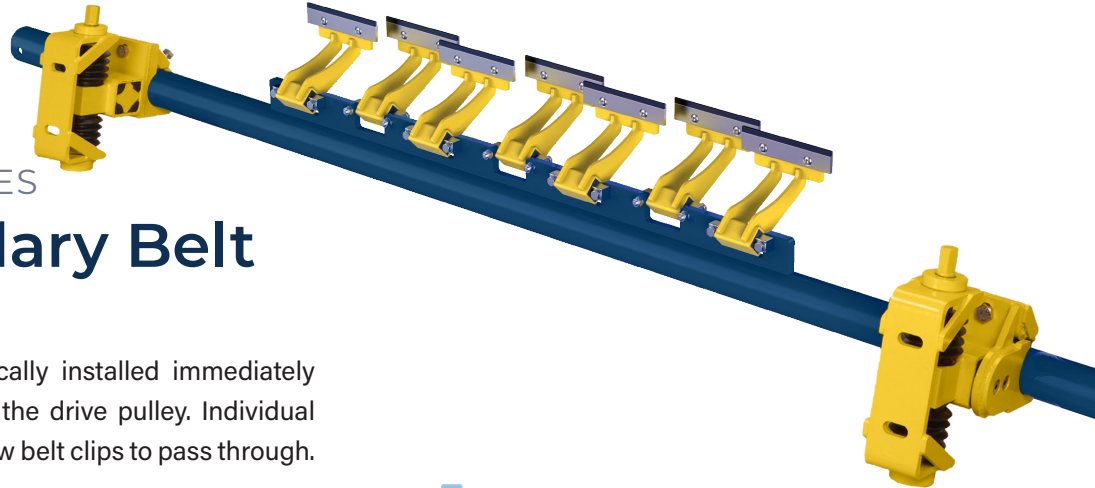

BXS5 FEATURES

- Belt Speed: 1200 ft./min. maximum
- Tensioners: Rosta, Pneumatic
- Blade Options: Tungsten Carbide or Ceramic
- Uses individual overlapping blades for efficient scraping
- Dual tensioning equipment for better pressure distribution
- Can be retrofitted to other brands

Belt Width	BLADE QTY.	TUNGSTEN CARBIDE	CERAMIC
18" (450mm)	4	BXS5-018-1T11Z	BXS5-018-1C11Z
24" (600mm)	5	BXS5-024-1T11Z	BXS5-024-1C11Z
30" (750mm)	7	BXS5-030-1T11Z	BXS5-030-1C11Z
36" (900mm)	8	BXS5-036-1T11Z	BXS5-036-1C11Z
42" (1050mm)	10	BXS5-042-1T12Z	BXS5-042-1C12Z
48" (1200mm)	11	BXS5-048-1T12Z	BXS5-048-1C12Z
54" (1350mm)	13	BXS5-054-1T13Z	BXS5-054-1C13Z
60" (1500mm)	15	BXS5-060-1T13Z	BXS5-060-1C13Z
72" (1800mm)	17	BXS5-072-1T13Z	BXS5-072-1C13Z
84" (2133mm)	21	BXS5-084-1T13Z	BXS5-084-1C13Z
Replacement Blades		BXS5-T	BXS5-C
Replacement Bases		BXS5-F	
Dual Rosta Tensioner (determined by belt width)		BSTZ100, BSTZ200, or BSTZ300	
Pneumatic Tensioner		BSPN100	

