

# **BENETECH.** **MaxClean**™

**BEP2-XXX-2U1B2**

**Production Class Primary  
Belt Cleaner System**

**Owner Operator  
&  
Manual**

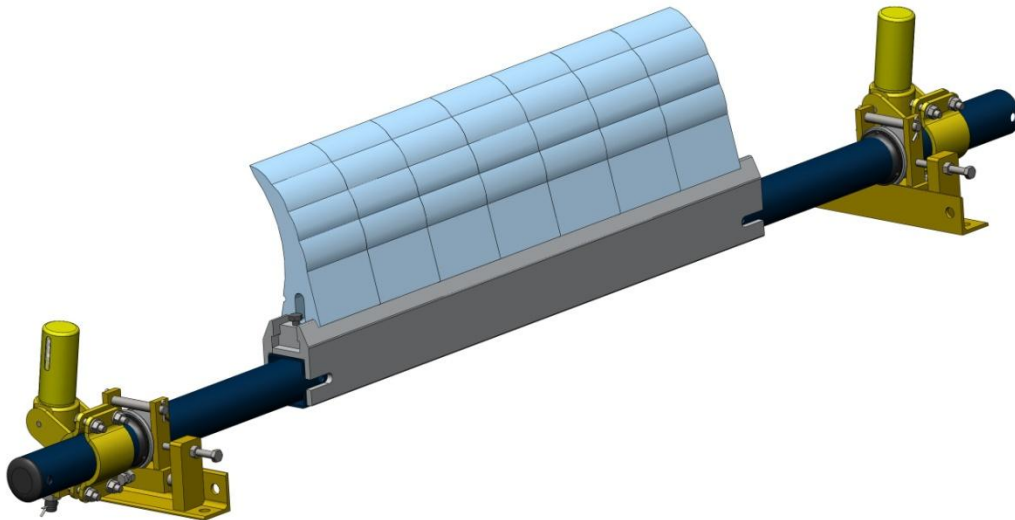

**BENETECH**® 

**! IMPORTANT !**

**BENETECH, INC. HEREBY DISCLAIMS ANY LIABILITY FOR, BUT NOT LIMITED TO:**

- IMPROPER INSTALLATION OF EQUIPMENT
- IMPROPER SIZING OF EQUIPMENT
- DAMAGE DUE TO CONTAMINATION OF MATERIAL
- USER'S FAILURE TO INSPECT EQUIPMENT
- USER'S FAILURE TO MAINTAIN EQUIPMENT
- USER'S FAILURE TO TAKE REASONABLE CARE OF THE EQUIPMENT
- INJURIES OR DAMAGE RESULTING FROM USE OR APPLICATION OF THIS PRODUCT CONTRARY TO INSTRUCTIONS AND SPECIFICATIONS CONTAINED HEREIN.

**BENETECH, INC.'S LIABILITY SHALL BE LIMITED TO REPAIR OR REPLACEMENT OF EQUIPMENT SHOWN TO BE DEFECTIVE.**

**! SAFETY !**

Review and understand all safety rules given herein along with local and Governmental standards and regulations. Know and understand the American National Standards Institute (ANSI) z244.1-1982 lockout/tagout procedures, the American National Standard for Personnel Protection - Lockout/Tagout of Energy Sources - Minimum Safety Requirements and the Occupational Safety and Health Administration (OSHA) Federal Register, Part IV, 29 CFR Part 1910, Control of Hazardous Energy Source (Lockout/Tagout); Final Rule.

Also observe all local and Governmental regulations concerning entry into confined spaces, welding, cutting, grinding, wash-down procedures and all Personal Protective Equipment (PPE) regulations.

*The following notations are used throughout in this manual.*

**! DANGER !**

**Danger:** Denotes immediate hazards that will result in severe personal injury or death.

**! WARNING !**

**Warning:** Denotes hazards or unsafe practices that could result in personal injury.

**! CAUTION !**

**Caution:** Denotes hazards or unsafe practices that could result in product or property damages.

**! IMPORTANT !**

**Important:** Denotes instructions that must be followed for proper installation and/or operation of equipment.

**! NOTE !**

**Note:** Denotes general items to assist the reader/ installer/ operator.

\*\*\*

***Please pay close attention to all of these items and warnings.  
They have been included here for your safety and for ease of installation.***

# Table of Contents

<b>Introduction.....</b>	<b>4</b>
<b>References.....</b>	<b>4</b>
<b>Installations Without Chutework.....</b>	<b>5</b>
<b>Safety .....</b>	<b>5</b>
<b>Belt Cleaner Inspection Access .....</b>	<b>5-6</b>
<b>Before Installing Belt Cleaner .....</b>	<b>7</b>
<b>Installing Belt Cleaner .....</b>	<b>8-15</b>
<b>Belt Cleaner Operation and Maintenance.....</b>	<b>16-17</b>
<b>Troubleshooting/Installation Checklist.....</b>	<b>18</b>
<b>Part Numbers.....</b>	<b>19</b>

# Introduction

The Primary Belt Cleaning System is installed on the face of the head pulley to aid in the removal of material sticking to the belt after the main material stream has been discharged from the belt. The remaining material sticking to the belt is “carried-back” by the “return strand” of the belt to nearly all areas of the conveyor.

This “carry-back” is then deposited in piles under the conveyor, sticks to return idlers, sticks gravity take-up pulleys, sticks to bend pulleys and sticks to or covers anything else it comes in contact with.

Problems arising from this carry-back can range from mis-tracking of belts due to uneven build up of material on idlers, to premature belt wear from the belt being dragged through material piles and into conveyor structural members, and belt fires from the belt being dragged through material piles and even complete catastrophic belt failure from pulleys seizing.

In most cases a dual cleaner system will be used with a Secondary Cleaner installed immediately following the Primary Cleaner. The Secondary Cleaner will remove stubborn material left on the belt by the Primary Cleaner. Installation and operating instructions for the particular type of Secondary Cleaner will be detailed in a separate manual shipped with the cleaner.

In some cases the materials used in the construction of the cleaners may not be compatible with the material being handled and contamination can occur if the product is damaged during use of even when it operates as intended. If the material handling process could be contaminated in any way through the use of this product it is the user's responsibility to take the necessary steps to prevent contamination.

Please feel free to consult BENETECH, INC. if you suspect there may be incompatibility problems or questions about product application and use, we can provide specific recommendations for your particular problem.

# References

The following documents are referenced in this manual:

- American National Standards Institute (ANSI) z244.1-1982, American National Standard for Personnel Protection - Lockout/Tagout of Energy Sources - Minimum Safety Requirements, American National Standards Institute Inc., 1430 Broadway, New York, NY 10018.
- Federal Register, Volume 54, Number 169, Part IV, 29 CFR Part 1910, Control of Hazardous Energy Source (Lockout/Tagout); Final Rule, Department of Labor, Occupational Safety and Health Administration (OSHA), 32nd Floor, Room 3244, 230 South Dearborn Street, Chicago, IL 60604.

## Installations without Chutework

These procedures were written for equipment that is being installed on enclosed head-pulley chutework. If the head-pulley is open (not enclosed) the equipment should be installed so that the critical dimensions are followed for proper installation.

## Belt Cleaner Inspection Access

If the belt cleaner is installed on enclosed pulley chutework, an Inspection Door must be installed to allow for inspecting the equipment during operation. If the chutework does not already have access doors that allow for installing, servicing and maintaining the equipment an adequate sized door should be used. Inspection doors are available from BENETECH, INC. or a representative. Contact BENETECH, INC. for a list of Benetech Inspection Doors and part numbers. **Unless specifically ordered, inspection doors are NOT included with belt cleaner.**

## Belt Cleaner Safety

*All safety rules defined in this document and all owner/employer as well as State and Federal safety rules must be strictly adhered to when working on/with this, or any, belt cleaner.*

**! DANGER !**

***Do not touch or go near the conveyor belt or conveyor accessories when the belt is running. Your body or clothing can get caught and you can be pulled into the conveyor, resulting in severe injury or death.***



**! DANGER !**

*Before installing, servicing, or adjusting the belt cleaner, turn off AND lock out/tag out all energy sources to the conveyor and conveyor accessories according to ANSI standards. Failure to do so could result in serious injury or death.*

**! DANGER !**

*If this equipment is to be installed in an enclosed area, observe all confined space entry regulations and test the atmosphere for gas levels and dust content levels before using a cutting torch, welding equipment or electric hand tools. Using a torch, welding, grinding or drilling in an area with gas or dust may cause an explosion and/or fire resulting in serious injury or death.*

**! WARNING !**

*Before using a cutting torch, welders, or grinding equipment, cover the conveyor belt with a fire retardant/resistant cover. Make sure a water source/fire hose is readily available AND OPERATIONAL. Failure to do so can allow the belt to catch fire.*

**! WARNING !**

*Belt cleaners are heavy and require two people to lift. Attempting to lift the belt cleaner without assistance could result in injuries or damage to the equipment.*



**! WARNING !**

*Remove all tools, parts, trash, and foreign objects from the installation area and conveyor belt before turning on the conveyor. Failure to do so can result in serious injury to personnel or damage the belt and conveyor.*

# Before Installing Belt Cleaner

1. Inspect ALL shipping containers for damage and correct number of items (skids, pallets, cartons, boxes, etc.) being delivered. Report damage and/or shortages to delivery service immediately and fill out delivery service's claim form. Keep ALL damaged goods for examination. Benetech Inc is NOT responsible for damage occurring during transit.
2. All Benetech Inc. belt cleaners are shipped from our facilities fully assembled. Care should be taken while disassembling the units to ensure no parts are lost or damaged as the equipment is moved to its desired location. Dispose of shipping containers in approved manner.
3. If any items are missing, IMMEDIATELY contact BENETECH, INC. or an authorized representative.
4. Gather tools. Minimum tools required for installation are:
  - Tape measure/ String
  - Torch/Hole Saw
  - Level/Straight Edge
  - Welder/Drill
  - Open/Box End Wrenches
  - Socket Set
  - Marker/Soapstone (Welders chalk)
5. Turn off and lock out/tag out energy source according to ANSI standards (see "References") and local plant regulations.

## **! WARNING !**

***Before installing equipment, turn off AND lock out/tag out all energy sources to the conveyor and conveyor accessories according to ANSI standards. Failure to do so could result in serious injury or death.***



6. If using a cutting torch or welding, test atmosphere for gas level or dust content. Cover conveyor belt with fire retardant cover. Verify locations of fire extinguishers and operational water hoses prior to begin cutting/welding operations.

## **! WARNING !**

***If equipment will be installed in an enclosed area, the atmosphere in the structure/area must be tested for gas levels and dust content levels before using a cutting torch, welding equipment, grinding equipment or electric powered tools. Using a cutting torch, welding, drilling or grinding in an area with gas or dust may cause an explosion.***

# Locating and Installing Belt Cleaner

## **! IMPORTANT !**

Read entire section before beginning work.

To install the belt cleaner, follow the steps detailed in this section.

1. Find center point of belt cleaner mainframe on both sides of chute work.
2. Locate mount bracket and far side mount bracket on chute walls.
3. Install far side mount plate and tensioner
4. Install near-side mount plate tensioner.
5. Install blade mounting pole
6. Install blades and cartridge on belt cleaner pole weldment/frame
7. Adjust tensioners and put into operation.

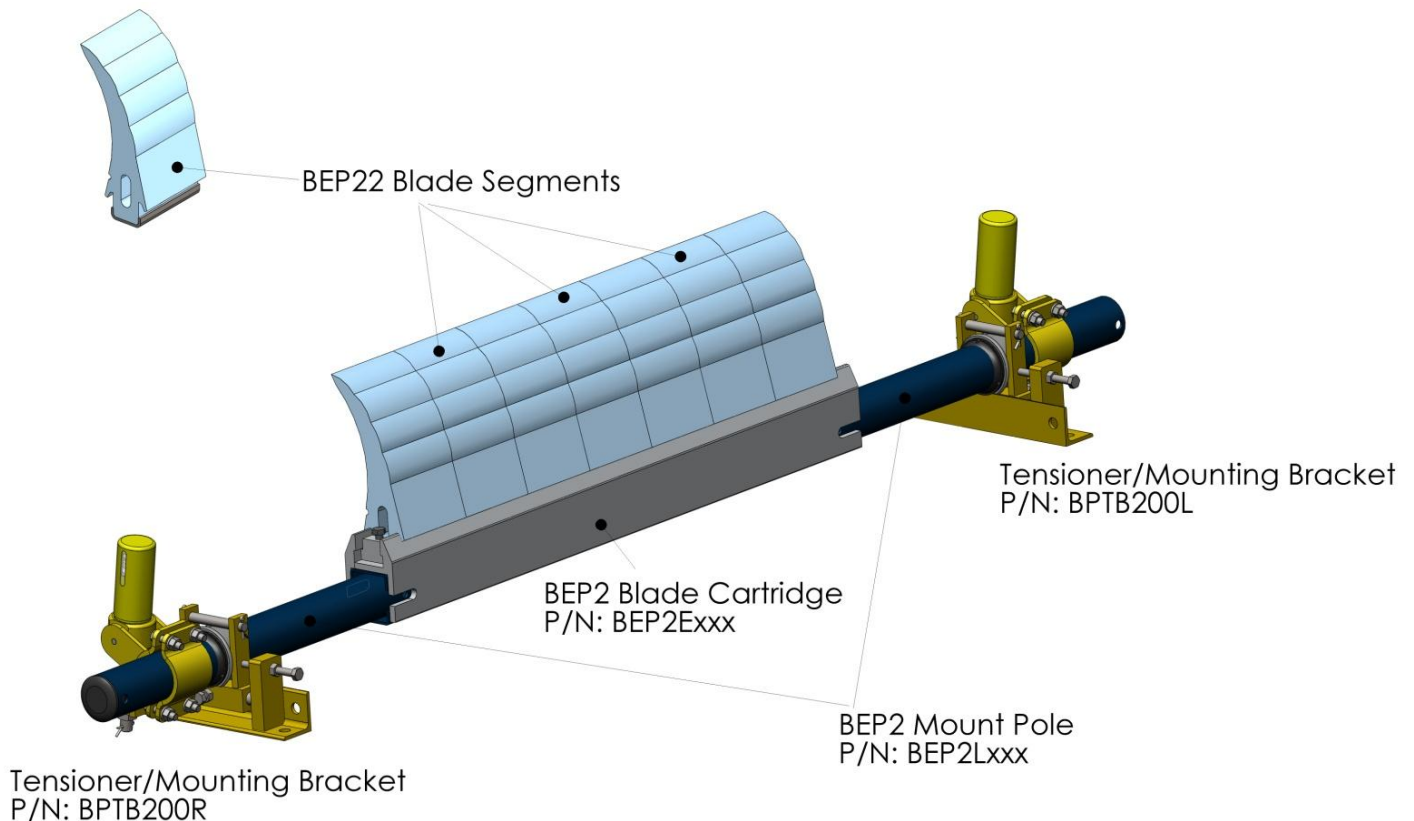

**Figure 1**



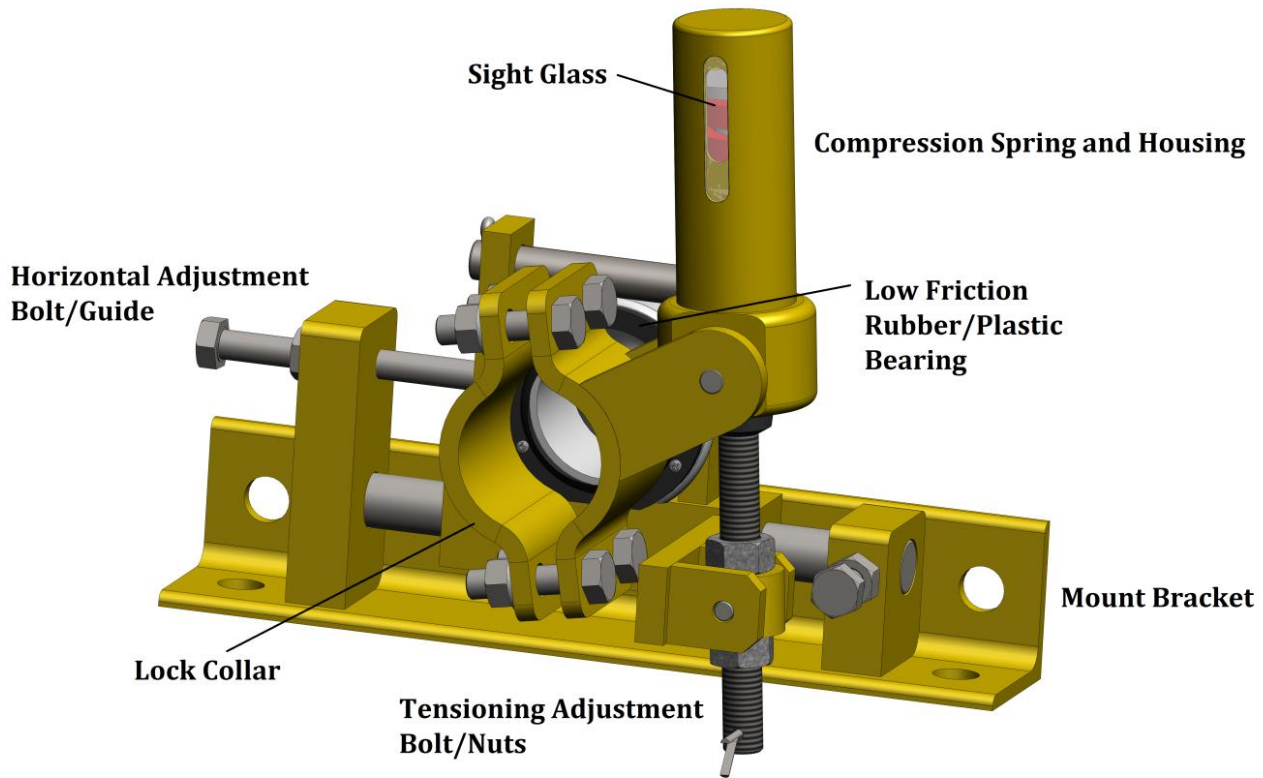

**Figure 2**

**1) Finding Center Point of Mainframe (See Figure 3 and Table 1)**

- a. On operator side chute wall, draw horizontal center line of head pulley as shown.
- b. Draw a second horizontal line (parallel to the line drawn in step a) 13.75" Min. as shown.
- c. Divide actual Head Pulley Diameter by 2. Add Head Pulley radius, pulley lagging (cover) thickness and belt thickness together. This gives Head Pulley Radius and Belt Thickness.
- d. Using Head Pulley Radius and Belt Thickness times 2 in Table 1, find "X" Dimension and add to Head Pulley Radius, from step 4, to get Arc Radius Length.

$$\text{Pulley Diameter}^* = (R_{\text{head}} + T_{\text{lagging}} + T_{\text{belt}}) * 2$$

$R_{\text{head}}$  - head pulley radius, inches (mm)

$T_{\text{lagging}}$  - lagging thickness, inches (mm)

$T_{\text{belt}}$  - belt thickness, inches (mm)

Find X dimension required in Table 1

$$\text{Arc Radius} = \text{Pulley Diameter} + X$$

- e. Using Arc Radius Length from step d, draw arc as shown.

Intersection of lower horizontal line and arc is center point for mainframe when the cleaner tips as horizontal to the head pulley.

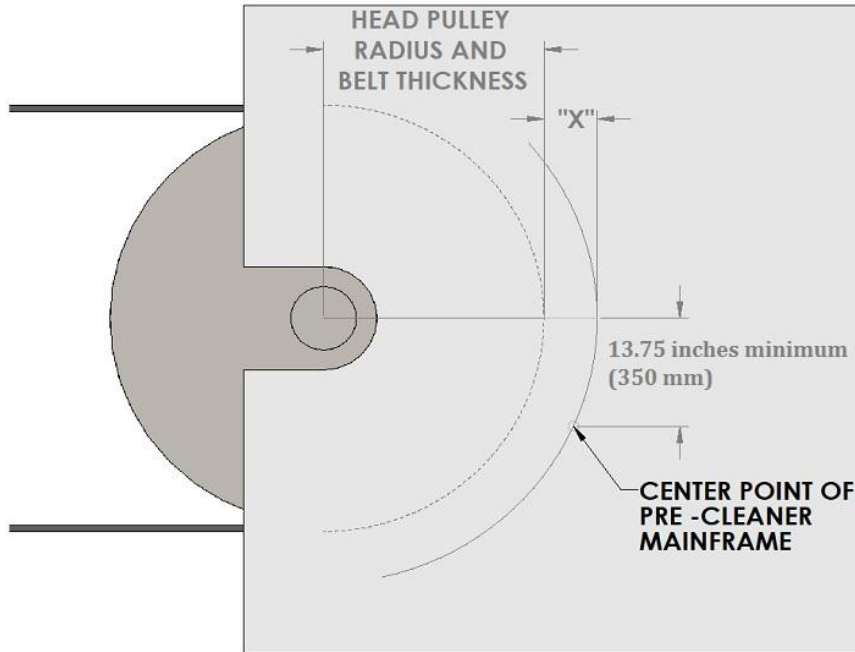

**Figure 3**

**Table1. Dimensions for locating BEP2 primary belt cleaner**

pulley diameter*		X	
in	mm	in	mm
18	457	5.5	140
20	508	5.25	133
22	559	5	127
24	610	5	127
26	660	5	127
28	711	4.75	121
30 or more	762 or more	4.5	114

**\*Includes lagging & belt. For smaller diameters, contact Benetech.**

- 2) Locate/Cut access hole for far side opening. Locate and drill holes for mounting bracket (top of bracket should line up with bottom of access window). Use X from Table1 above and the dimensions shown in Figure 4.
  - a. Repeat for the near side mounting
  - b. If using an Inspection Door, install it according to the Inspection Door Operator's Manual. Insure that Inspection Door is installed close enough and is sized large enough to allow for inspection, maintenance and service of equipment.

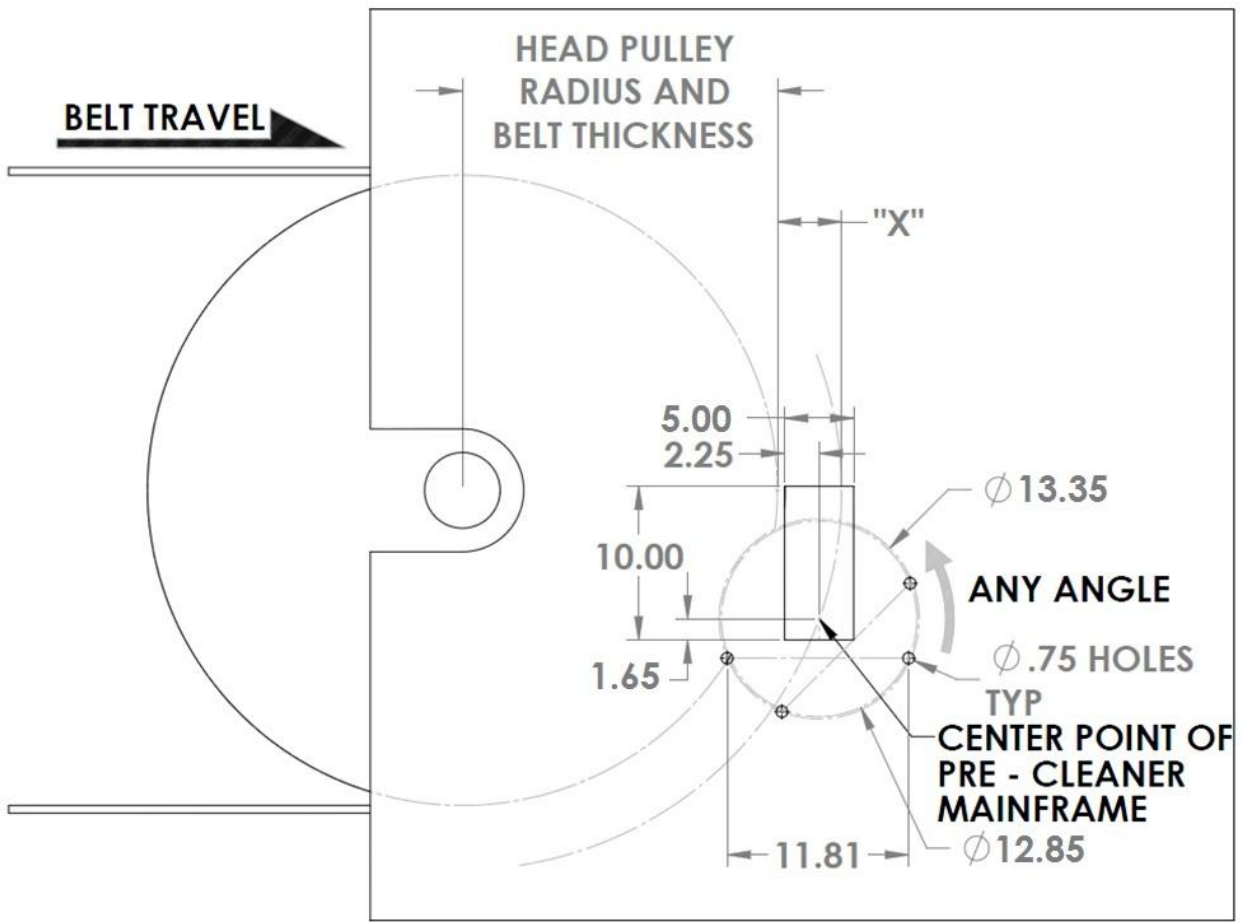

**Figure 4: Hole Cutout Template**

Note: Mounting Bracket can be installed in multiple positions (angles) if space is limited, Figure 4.

- 3) Loosely bolt far side mount bracket and tensioner to chute wall. Loosen lock collar (Figure 2)
- 4) Loosely bolt near side mount bracket and tensioner to chute wall. Loosen lock collar (Figure 2).

**! WARNING !**

***Belt cleaner is very heavy and requires a hoist or several people to lift. Attempting to lift belt cleaner without assistance could result in serious injury.***



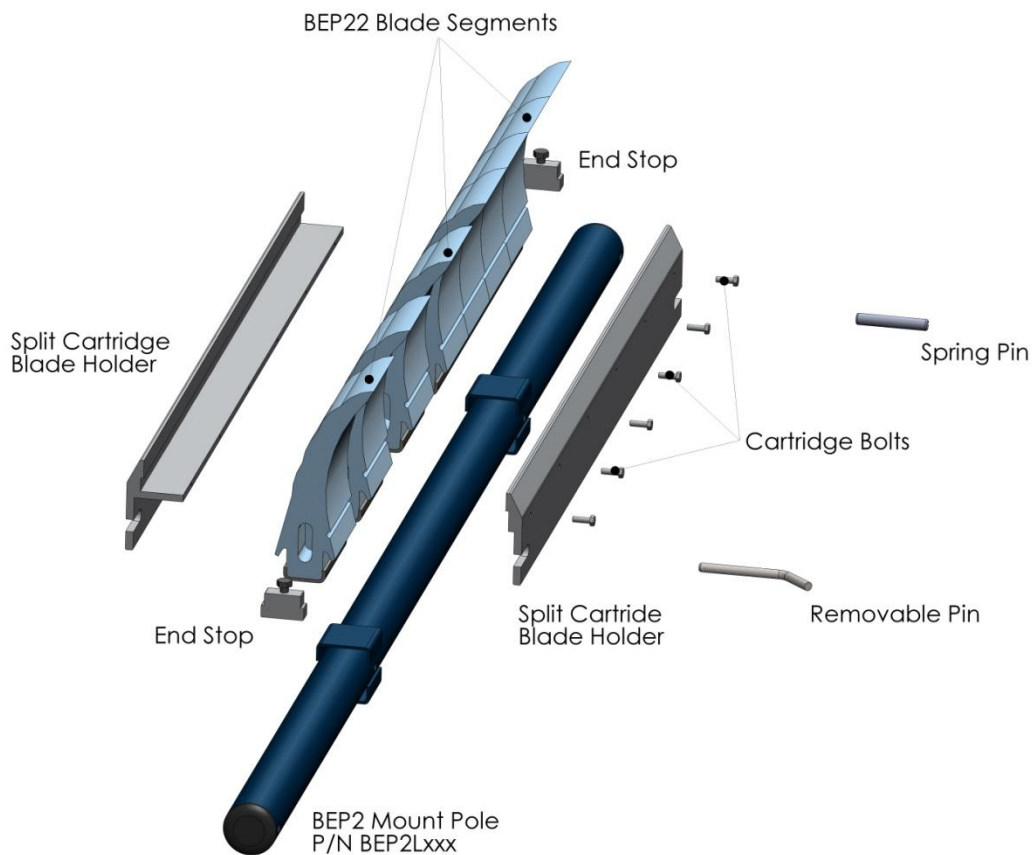
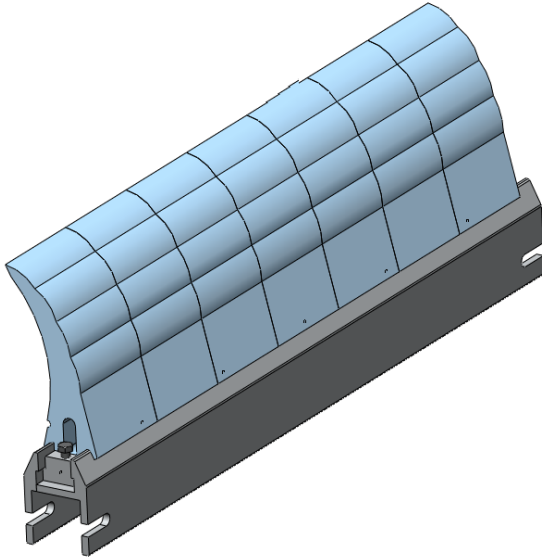

**Figure 5**

5) Installing Belt Cleaner Assembly

- a. Remove pins from pole/mainframe weldment
- b. Remove cartridge and blades from pole/mainframe weldment.
- c. Reverse procedure for reassembly after pole weldment/mainframe is installed in the chute.
- d. Slide pole weldment (Item #1) into chute wall holes and through the plastic bearing in each tensioner/mounting bracket (Figure 2 and Figure 5) and through tensioner/mount bracket lock colors. do not tighten.
- e. Assemble Blades and Cartridge
  - i. The BEP2 is a cartridge belt cleaner (figure?), consisting of individual/segmented blades that fit into a track/cartridge that is then affixed to the mainframe/mounting pole. if the blades are installed on the track skip this section.

1. To install the blades on the track loosen the bolts holding the two cartridge pieces together and slide the blades on individually, pressing them together for a tight fit with no gaps. blade quantity versus belt width is shown in Table ?
2. Center the blades on the cartridge, tighten the cartridge bolts on the cartridge to lock the blades securely into the cartridge.
3. Slide the end stops into the cartridge and tighten the set screw bolt.
4. Ensure all hardware is tightened.



Belt Width		BEP22 Quantity	Cartridge P/N
in	mm		
18	450	2	BEP2E018
24	600	3	BEP2E024
30	750	4	BEP2E030
36	900	5	BEP2E036
42	1050	6	BEP2E042
48	1200	7	BEP2E048
54	1400	8	BEP2E054
60	1600	9	BEP2E060
72	1800	10	BEP2E072
84	2200	12	BEP2E084

**Figure 6**

- f. Mount the cartridge to the pole
  - i. The removable pin should be placed on side with inspection door or easiest access. the cartridge can then be removed easily when its time for blade replacement/changeout.
- g. Rotate blades until the tip of the blades come into contact with the surface of the conveyor belt.
- h. Ensure the tips of the blades come into contact with the conveyor belt at the same time. adjustments can be made to fine tune the position of the frame by adjusting the horizontal adjustment bolts on either of the tensioner/mounting brackets
- i. Ensure that the blades are centered on the conveyor belt.
- j. Tighten the lock collars around the pole on the tensioning/mount brackets
- k. Verify the installation dimensions in step 1,2, and 3.
- l. Verify the blades are centered on the conveyor belt and that the blade tips are in the recommended operating position.
- m. Tighten bolts securing mounting bracket and tensioner to the chute wall on both near and far sides
- n. Tighten lock collars on both near and far side tensioners to secure blade against belt. note that the compression spring should be completely relaxed (uncompressed).

**! CAUTION !**

***Belt cleaner blades should be centered to clean area narrower than conveyor belt width. This allows movement of belt and prevents damage to edge of belt.***

6) Adjusting tensioners and putting cleaner into operation

- a. Ensure the blade tip is in contact with the head pulley across the full width of the blade. Slight adjustments to line the blade tip up with the belt surface can be done by adjusting the pole weldment position with the horizontal adjustment bolt (Figure 2) on each tensioner/mounting block assembly.
- b. Starting on near side adjust tensioning bolt until compression spring is activated. Note "zero" position of spring in sight glass as tensioning bolt is adjusted (when the spring is actuated the nut will be much harder to turn).
- c. Continue to turn the lower nut to adjust the length of the tensioning bolt. Monitor the deflection of the spring in the sight glass by watching the base of the spring move from the zero point/start line as you turn the nut. Keep turning until you the base of the spring is in the center of the marked lines on the site glass, see figure ?.
  - i. Springs are sized for belt width. recommended setting is with the base of the spring located on the center line marking of the sight glass. adjust as needed.

**Spring Tensioner Springs**

Belt Width		Spring Color
18"-42"	450 mm-1050 mm	Blue
48"-84"	1200 mm-2200 mm	Red

- d. Repeat for the far side tensioner.
- e. Check near side tensioner compression again.
- f. Repeat steps d&e until both tensioners are set at the recommended settings.

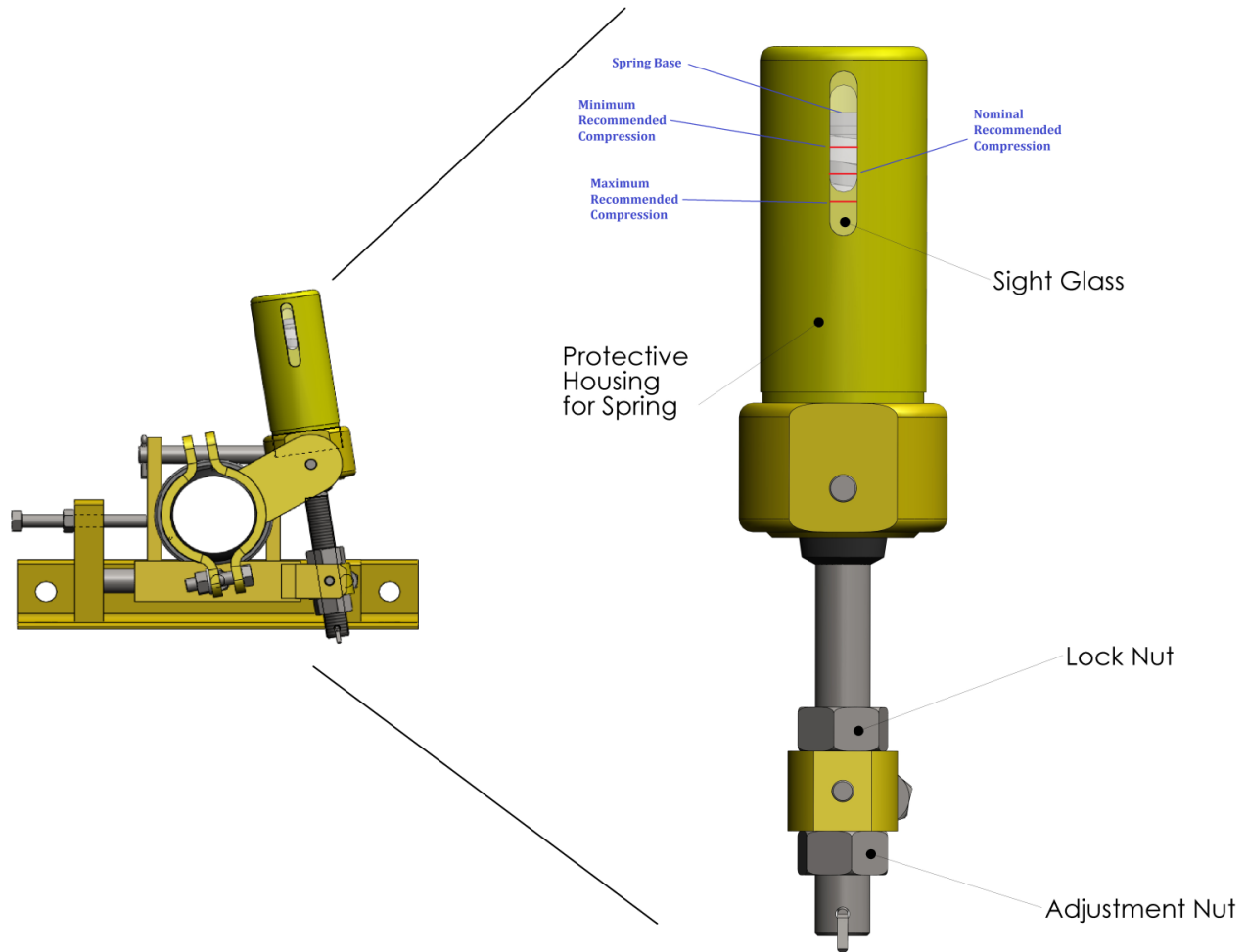

**Figure 7**

**! WARNING !**

*Excessive tensioning of the belt cleaner can create premature wear of cleaner blades, damage to belt cover and excessive heat.*

**! DANGER !**

*Excessive heat created by excessive friction due to cleaners being improperly tensioned can create situations where fire and or explosions can occur*

**! WARNING !**

*Failure to remove tools from installation area and conveyor belt before turning on energy source can cause serious injury to personnel and damage to belt.*

**! WARNING !**

*Do not touch or go near conveyor belt or conveyor accessories when conveyor belt is running. Body or clothing can get caught and pull body into conveyor belt, causing severe injury or death.*

# Belt Cleaner Operation and Maintenance



- 1) Once installation is complete turn on conveyor belt for 1/2 hour, then turn off. Tighten all mounting nuts, bolts, etc. Check for belt condition and proper tensioner settings. Readjust if necessary.

## **! DANGER !**

**Before installing, servicing, or adjusting the belt cleaner/tensioner, turn off and lock out/tag out all energy sources to the conveyor and conveyor accessories according to ANSI standards. Failure to do so could result in serious injury or death.**



- 2) Periodic inspection and maintenance **MUST** be performed on a regular basis to ensure the equipment is functioning properly.
  - a. Inspect belt cleaner for proper wear pattern. A small amount of “run-in” wear is normal. This will stop once blades wear to conveyor belt contour. The blade should wear evenly during operation - if it doesn't contact Benetech Inc.
  - b. If excess or uneven wear patterns appear, material builds up badly on blades or frame, or some other problem exists, consult a specialist or contact Benetech Inc for support.
  - c. During inspection remove any material build-up from belt cleaner.
  - d. Make sure all fasteners are tight on tensioners and mounting blocks. Tighten if necessary.
  - e. Check compression/deflection on tensioner springs. Re-tension if necessary. Note that as the blades wear out the tensioners will need to be adjusted
  - f. Check blades for excessive wear. All Benetech Inc. blades come with a visible wear lines or patterns on the back of the blades indicating when scraper blades should be replaced. Replace blades when necessary.



- g. Remove equipment from service if there is any indication it is not functioning properly. Call BENETECH, INC. or a representative for assistance.

**! NOTE !**

Maintenance inspection should be performed no less than weekly. Some applications may require more frequent maintenance inspections.

**! DANGER !**

*Before installing, servicing, or adjusting the belt cleaner/ tensioner, turn off and lock out/tag out all energy sources to the conveyor and conveyor accessories according to ANSI standards. Failure to do so could result in serious injury or death.*

**! WARNING !**

*Failure to remove tools from installation area and conveyor belt before turning on energy source can cause serious injury to personnel and damage to belt.*

**! WARNING !**

*Do not touch or go near conveyor belt or conveyor accessories when conveyor belt is running. Body or clothing can get caught and pull body into conveyor belt, causing severe injury or death.*

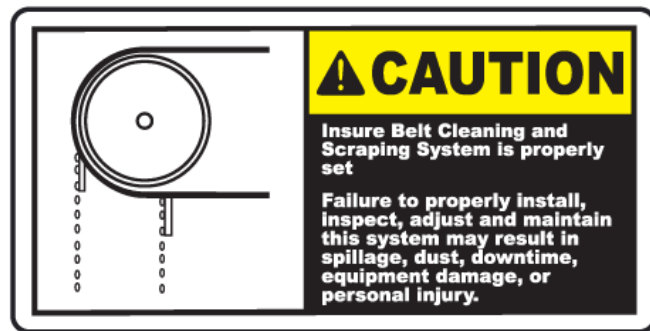

# Troubleshooting

## **! NOTE !**

Conveyor equipment is subject to a wide variety of bulk materials characteristics and performs under extreme operating conditions. It is not possible to predict all circumstances that may require troubleshooting. Contact BENETECH, INC. or a representative if you are experiencing problems other than those listed in the “Troubleshooting” section below. **Do not return the equipment to operation until the problem has been identified and corrected.**

## **Symptom Corrective Action**

### **Insufficient cleaning and excessive carry back.**

Tension of cleaner on belt is set too low. Increase tension to recommended settings or higher if necessary as bulk material conditions may have changed (monitor closely and return to original/recommended settings when possible).

### **Blades are worn.**

Blades are designed to wear during operation. Clear indicator lines or blade pattern indicate when blades are to be removed from service and replaced.

### **Noise or vibration.**

Tension is set too high or un-even between the two tensioners. Correct or equalize tension on both tensioners as necessary. If this does not correct the problem, blade type or urethane type may not match application. Cleaner may also be incorrectly mounted or other damage to the cleaning system may have occurred. Contact Benetech, Inc. or a representative.

### **High blade wear rate requiring frequent blade replacement or changeouts.**

Cleaner tension on belt is set too high. Reduce tensioner setting. If problem persists contact Benetech Inc. or a representative.

### **Unusual wear or damage to blades.**

Check belt splice(s) and repair as necessary. Observe belt operation and check for irregularities. If the cleaning system is damaged replace it. If blades are worn out replace them. If blades are not worn, check mainframe location.

### **Blade or System Corrosion/Chemical Degradation.**

Blade urethane may not match application. Contact BENETECH, INC. or a representative.

### **Other problems.**

Contact BENETECH, INC. or a representative.

# Part Numbers

This section provides product names and corresponding part numbers for the Benetech BEP2-XXX-2U1B2 Production Class Primary Belt Cleaner System. For a more detailed parts list please contact Benetech Inc.

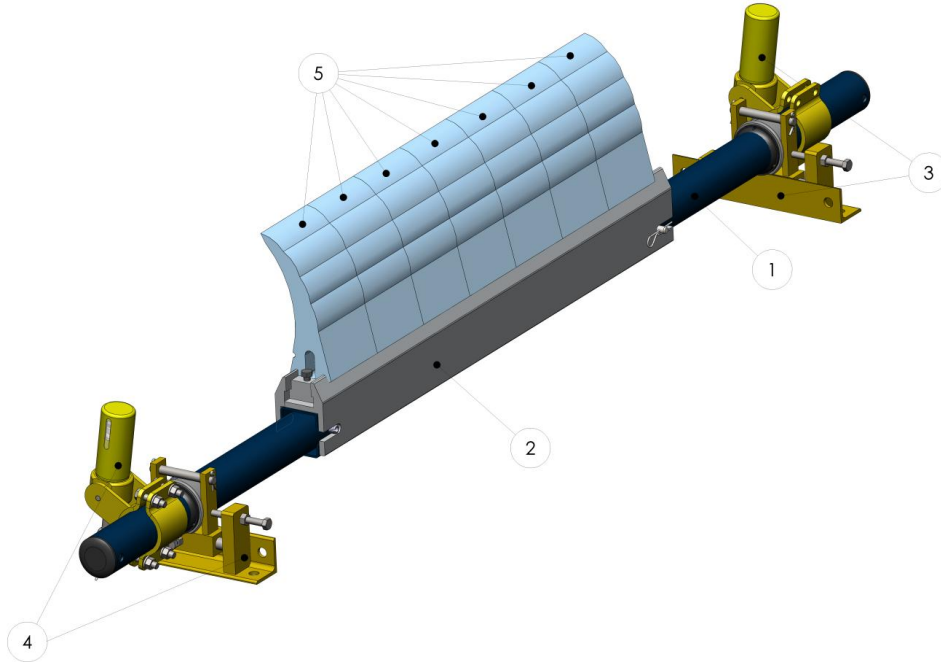

## BEP2-xxx-2U1B2 Production Class Primary Belt Cleaner System

Item	Description	Part Number	Qty
1	Pole Weldment/Frame	BEP2Lxxx	1
2	Cartridge/Extrusion	BEP2Exxx	1
	Tensioner/Mount Bracket (Pair)	BPTB200	1
3	Tensioner/Mount Bracket (LHS)	BPTB200L	1
4	Tensioner/Mount Bracket (RHS)	BPTB200R	1
5	BEP2 Blade Segment	BEP22	Table Below
NS	Owner-Operator Manual	Contact Benetech Inc	1

XXX\* Indicates belt width in inches.

NS – Not Shown

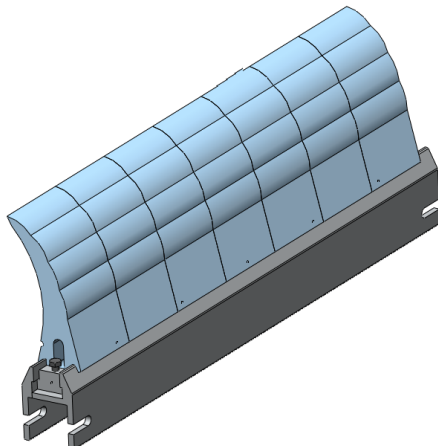

Belt Width		BEP22	Cartridge
in	mm	Quantity	P/N
18	450	2	BEP2E018
24	600	3	BEP2E024
30	750	4	BEP2E030
36	900	5	BEP2E036
42	1050	6	BEP2E042
48	1200	7	BEP2E048
54	1400	8	BEP2E054
60	1600	9	BEP2E060
72	1800	10	BEP2E072
84	2200	12	BEP2E084

---

Benetech, Inc  
2245 Sequoia Drive  
Suite 300  
Aurora, IL 60506

P: 630-844-1300  
F: 630-844-8690  
[www.benetechusa.com](http://www.benetechusa.com)

BEP2-22812