

BENETECH[®]

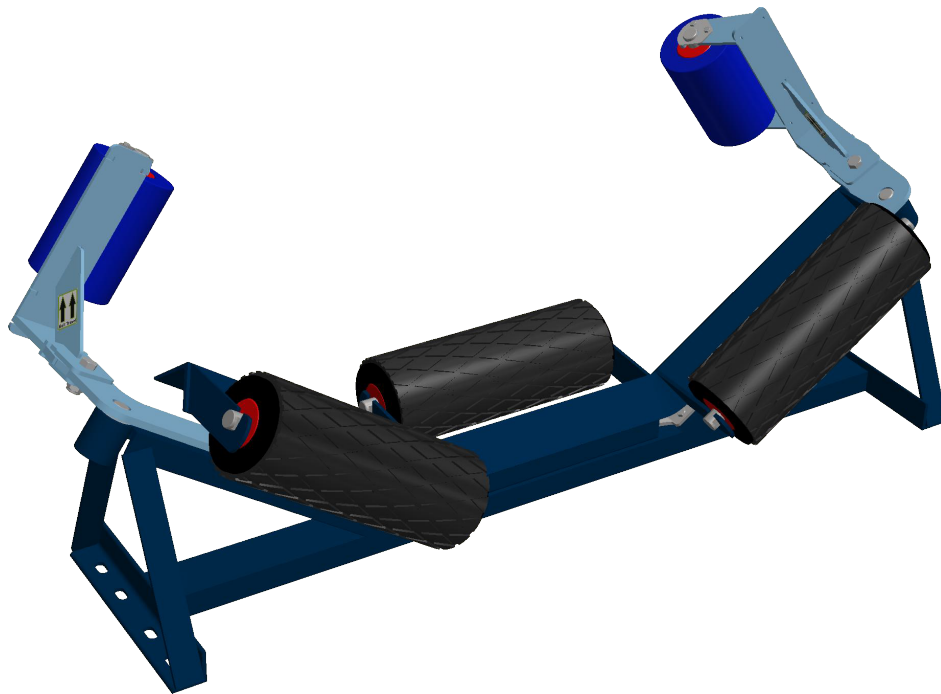

Troughing Idler



Installation Manual

! IMPORTANT !

BENETECH, INC. HEREBY DISCLAIMS ANY LIABILITY FOR, BUT NOT LIMITED TO:

- IMPROPER INSTALLATION OF EQUIPMENT
- IMPROPER SIZING OF EQUIPMENT
- DAMAGE DUE TO CONTAMINATION OF MATERIAL
- USER'S FAILURE TO INSPECT EQUIPMENT
- USER'S FAILURE TO MAINTAIN EQUIPMENT
- USER'S FAILURE TO TAKE REASONABLE CARE OF THE EQUIPMENT
- INJURIES OR DAMAGE RESULTING FROM USE OR APPLICATION OF THIS PRODUCT CONTRARY TO INSTRUCTIONS AND SPECIFICATIONS CONTAINED HEREIN.

BENETECH, INC.'S LIABILITY SHALL BE LIMITED TO REPAIR OR REPLACEMENT OF EQUIPMENT SHOWN TO BE DEFECTIVE.

! SAFETY !

Review and understand all safety rules given herein along with local and Governmental standards and regulations. Know and understand the American National Standards Institute (ANSI) z244.1-1982 lockout/tagout procedures, the American National Standard for Personnel Protection - Lockout/Tagout of Energy Sources - Minimum Safety Requirements and the Occupational Safety and Health Administration (OSHA) Federal Register, Part IV, 29 CFR Part 1910, Control of Hazardous Energy Source (Lockout/Tagout); Final Rule.

Also observe all local and Governmental regulations concerning entry into confined spaces, welding, cutting, grinding, wash-down procedures and all Personal Protective Equipment (PPE) regulations.

The following notations are used throughout in this manual.

! DANGER !

Danger: Denotes immediate hazards that will result in severe personal injury or death.

! WARNING !

Warning: Denotes hazards or unsafe practices that could result in personal injury.

! IMPORTANT !

Important: Denotes instructions that must be followed for proper installation and/or operation of equipment.

NOTE

Note: Denotes general items to assist the reader/ installer/ operator.

Please pay close attention to all of these items and warnings.
They have been included here for your safety and for ease of installation.

All safety rules defined in this document and all owner/employer as well as State and Federal safety rules must be strictly adhered to when working on/with this, or any, conveyor plow system.



! DANGER !

Do not touch or go near the conveyor belt or conveyor accessories when the belt is running. Your body or clothing can get caught and you can be pulled into the conveyor, resulting in severe injury or death

! DANGER !

Before installing, servicing, or adjusting the plow, turn off AND lock out/tag out all energy sources to the conveyor and conveyor accessories according to ANSI standards. Failure to do so could result in serious injury or death.

! DANGER !

If this equipment is to be installed in an enclosed area, observe all confined space entry regulations and test the atmosphere for gas levels and dust content levels before using a cutting torch, welding equipment or electric hand tools. Using a torch, welding, grinding or drilling in an area with gas or dust may cause an explosion and/or fire resulting in serious injury or death.

! WARNING !

Before using a cutting torch, welders, or grinding equipment, cover the conveyor belt with a fire retardant/resistant cover. Make sure a water source/fire hose is readily available AND OPERATIONAL. Failure to do so can allow the belt to catch fire.

! WARNING !

Conveyor plows are heavy and may require two people to lift. Attempting to lift the plow without assistance could result in injuries or damage to the equipment.

Before Installing the Benetech Troughing Idler

1. Inspect ALL shipping containers for damage and correct number of items (skids, pallets, cartons, boxes, etc.) being delivered. Report damage and/or shortages to delivery service immediately and fill out delivery service's claim form. Keep ALL damaged goods for examination. Benetech Inc is NOT responsible for damage occurring during transit.
2. All Benetech Troughing Idler's are shipped from our facilities assembled. Care should be taken while disassembling the units to ensure no parts are lost or damaged as the equipment is moved to its desired location. Dispose of shipping containers in an approved manner.
3. If any items are missing, IMMEDIATELY contact BENETECH, INC. or an authorized representative.
4. Gather tools. Minimum tools required for installation are:
 - Tape measure/ String
 - Torch/Hole Saw
 - Level/Straight Edge
 - Welder/Drill
 - Open/Box End Wrenches
 - Socket Set
 - Marker/Soapstone (Welders chalk)
5. If using a cutting torch or welding, test atmosphere for gas level or dust content. Cover conveyor belt with fire retardant cover. Verify locations of fire extinguishers and operational water hoses prior to begin cutting/welding operations.



! WARNING !

Before installing equipment, turn off AND lock out/tag out all energy sources to the conveyor and conveyor accessories according to ANSI standards and local plant regulations. Failure to do so could result in serious injury or death.

If equipment will be installed in an enclosed area, the atmosphere in the structure/area must be tested for gas levels and dust content levels before using a cutting torch, welding equipment, grinding equipment or electric powered tools. Using a cutting torch, welding, drilling or grinding in an area with gas or dust may cause an explosion.

Once a problem area has been identified, it is important to adhere to the safety regulations regarding setup, maintenance and operational repairs.



1. If possible, run the conveyor until it is clear of all material.
2. Ensure that all workers have locked themselves from the system.

Important: Do not remove the strapping on the Benetech Troughing Idler® frame before installation. If strapping is removed at this stage, there is danger of injury to hands and damage to equipment.



3. **Caution:** Before installing a Benetech Troughing Idler® ensure that the power supply to the conveyor belt has been disconnected.



4. Disengage any takeups.
5. Ensure that your hole spacing and sizes on the frame are the same as on the foot brackets.
6. Remove the bolts from the frame where you intend to install the Benetech Troughing Idler®.
7. If possible reduce tension on the belt by raising the belt off the troughing frames by 400 mm.
8. Remove idlers from the existing frame.
9. Remove the existing frame which is to be replaced by the Benetech Troughing Idler® from the conveyor system.

Important: The Benetech Troughing Idler® is direction sensitive and therefore has to be installed correctly.

Each Benetech Troughing Idler® has Belt Direction Labels on the sensor arms of the frame as shown in *Figure 1*.

10. Clean the area where the Benetech Troughing Idler® frame feet will rest – Area indicated by No.2 in *Figure 2*.

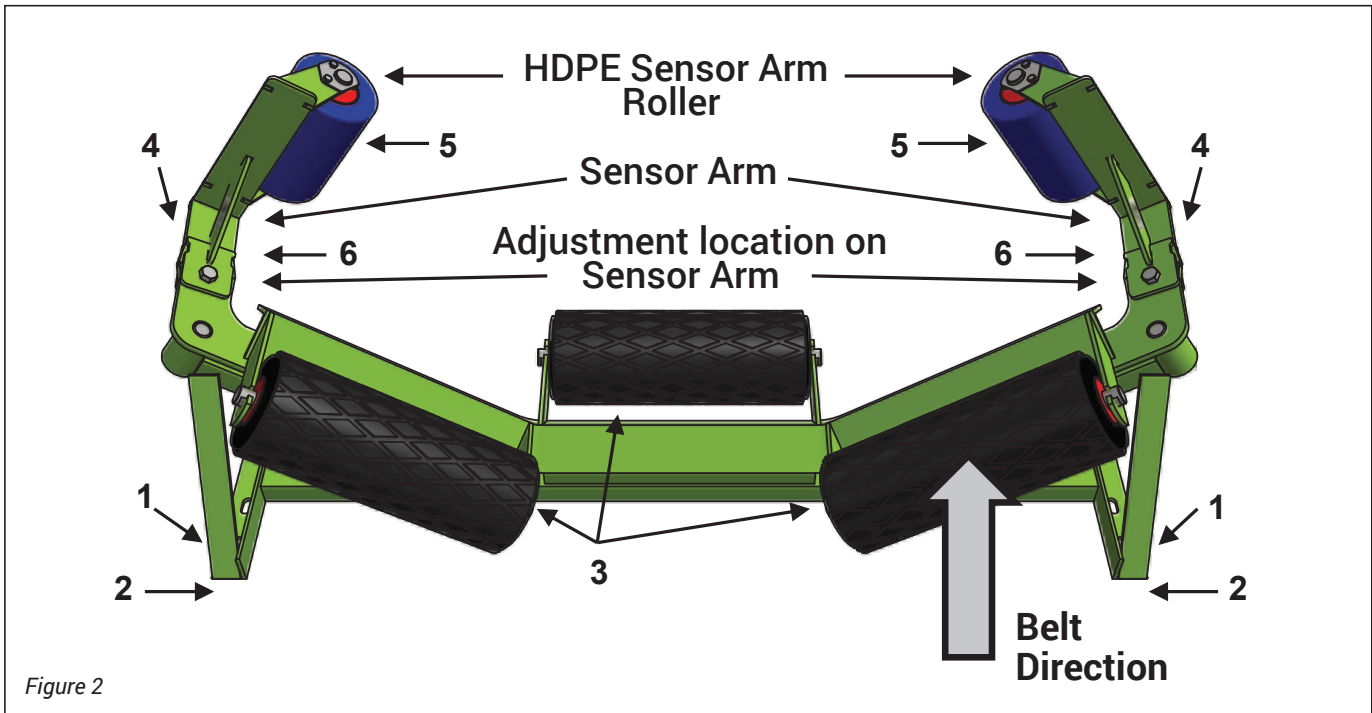
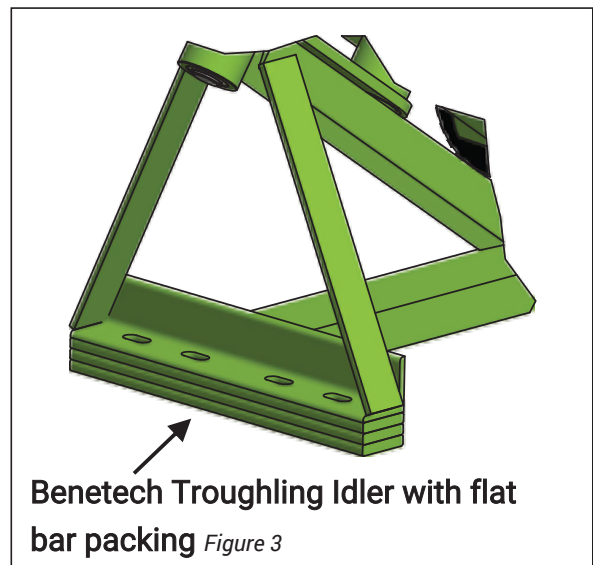

Figure 2

11. Install the Benetech Troughing Idler® frame into position and ensure that the frame is mounted perpendicular (90 degrees) to the structure and belt.
12. Install the rubber lagged idlers into the Benetech Troughing Idler® frame by locating the shaft ends into the brackets provided – Area indicated by No.3 in *Figure 2*.
13. Ensure that there is appropriate contact between the rubber lagged idlers and the conveyor belt. You can use packing between the Benetech Troughing Idler® and the structure at No.1 (*Figure 2*), as shown in *Figure 3*, to increase contact. If you need to decrease contact, use packing under previous and trailing frames.
14. Bolt the Benetech Troughing Idler® securely to the structure using new galvanized bolts and nuts, with washers, through the holes in the frame ends – Area indicated at No.1 and No.2 in *Figure 2*.



15. Mount the sensor arms to the Benetech Troughing Idler® frame (*Figure 4*)– Area indicated at No.4 in *Figure 2*.

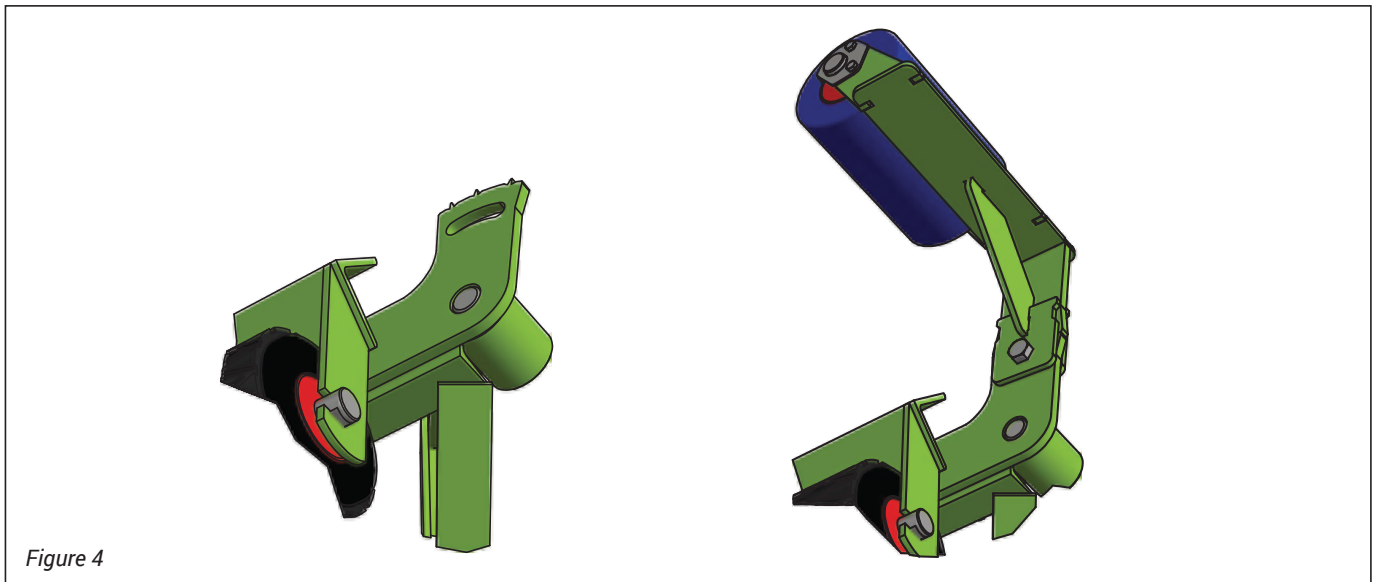

Figure 4

Important: Do not insert M12 x 40 hex bolts into the sensor arm as adjustment cannot take place when bolts are in.



16. Inspect the conveyor belt and adjust the sensor arms (Area No:4 in *Figure 2*) equally on the left and right. The conveyor belt must run in the centre of the frame and each sensor roller (Area No.5 in *Figure 2*) with approximately 15mm-20mm space between the belt edge and the roller.

Important: This spacing is critical and care should be taken to achieve this setting as accurately as possible using the teeth and notches on the mating parts of the arm - *Figure 6*.

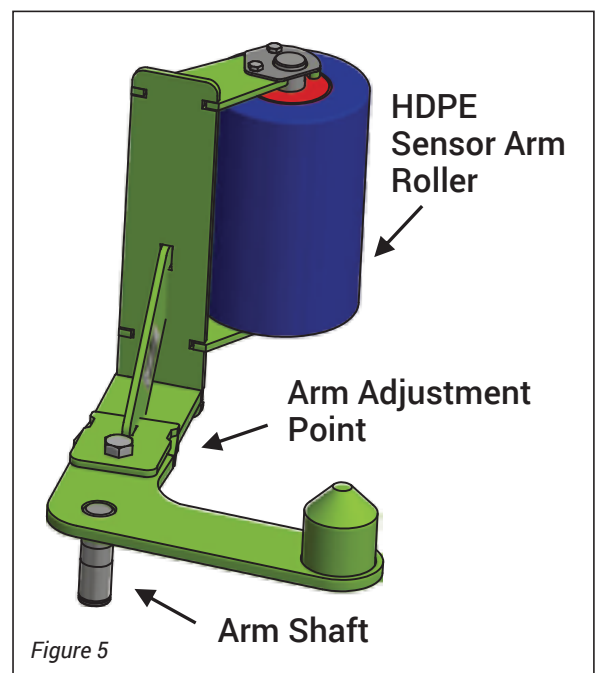
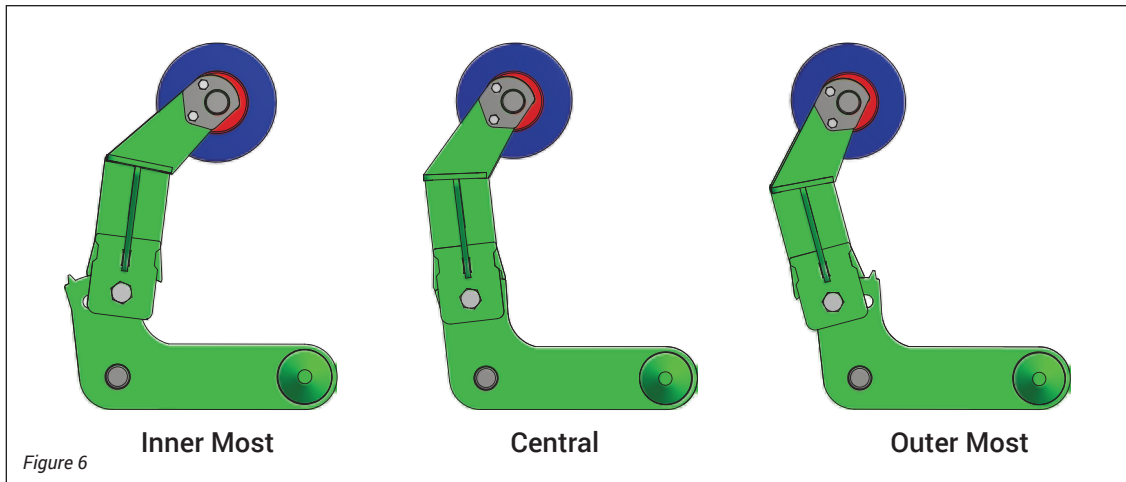

Figure 5

17. If the belt cannot be moved make the adjustments taking the misalignment into consideration.



18. Once the correct spacing has been achieved, lock the sensor arm with the setting screw on both sides as in *Figure 7*– Area indicated by No.6 in *Figure 2*.

19. Remove strapping.

20. Remove all tools and lifting equipment and clean the area around the Benetech Troughing Idler®. Make sure that nothing will come into contact with the frame and the conveyor belt.

21. Unlock the conveyor system and make sure that no people are on, or working on the conveyor.

22. Prepare to test the conveyor belt.

23. Run the conveyor belt for 15 minutes and test that the Benetech Troughing Idler® aligns the belt.

24. Monitor the conveyor belt system for any misalignment and spillage problems.

25. If necessary, make adjustments to the sensor arm or raise frame to increase contact with belt to achieve best tracking results.

26. If misalignment and spillage problems still occur, refer back to Benetech Troughing Idler® Troubleshooting Procedures to identify possible causes and solutions.

