

BENETECH[®]

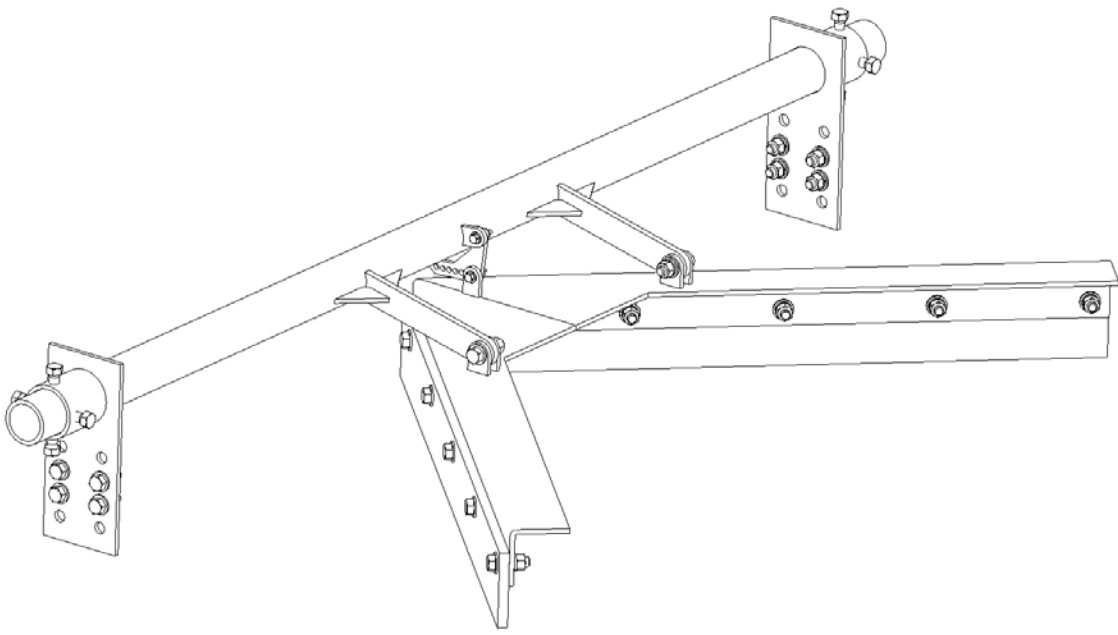

V-LOW BVP2-XXX-1RXC2

Installation Guide



! IMPORTANT !**BENETECH, INC. HEREBY DISCLAIMS ANY LIABILITY FOR, BUT NOT LIMITED TO:**

- IMPROPER INSTALLATION OF EQUIPMENT
- IMPROPER SIZING OF EQUIPMENT
- DAMAGE DUE TO CONTAMINATION OF MATERIAL
- USER'S FAILURE TO INSPECT EQUIPMENT
- USER'S FAILURE TO MAINTAIN EQUIPMENT
- USER'S FAILURE TO TAKE REASONABLE CARE OF THE EQUIPMENT
- INJURIES OR DAMAGE RESULTING FROM USE OR APPLICATION OF THIS PRODUCT CONTRARY TO INSTRUCTIONS AND SPECIFICATIONS CONTAINED HEREIN.

BENETECH, INC.'S LIABILITY SHALL BE LIMITED TO REPAIR OR REPLACEMENT OF EQUIPMENT SHOWN TO BE DEFECTIVE.**! SAFETY !**

Review and understand all safety rules given herein along with local and Governmental standards and regulations. Know and understand the American National Standards Institute (ANSI) z244.1-1982 lockout/tagout procedures, the American National Standard for Personnel Protection - Lockout/Tagout of Energy Sources - Minimum Safety Requirements and the Occupational Safety and Health Administration (OSHA) Federal Register, Part IV, 29 CFR Part 1910, Control of Hazardous Energy Source (Lockout/Tagout); Final Rule. Also observe all local and Governmental regulations concerning entry into confined spaces, welding, cutting, grinding, wash-down procedures and all Personal Protective Equipment (PPE) regulations.

The following notations are used throughout in this manual.

! DANGER !

Danger: Denotes immediate hazards that will result in severe personal injury or death.

! WARNING !

Warning: Denotes hazards or unsafe practices that could result in personal injury.

! IMPORTANT !

Important: Denotes instructions that must be followed for proper installation and/or operation of equipment.

NOTE

Note: Denotes general items to assist the reader/ installer/ operator.

Please pay close attention to all of these items and warnings.
They have been included here for your safety and for ease of installation.

All safety rules defined in this document and all owner/employer as well as State and Federal safety rules must be strictly adhered to when working on/with this, or any, conveyor plow system.



! DANGER !

Do not touch or go near the conveyor belt or conveyor accessories when the belt is running. Your body or clothing can get caught and you can be pulled into the conveyor, resulting in severe injury or death

! DANGER !

Before installing, servicing, or adjusting the plow, turn off AND lock out/tag out all energy sources to the conveyor and conveyor accessories according to ANSI standards. Failure to do so could result in serious injury or death.

! DANGER !

If this equipment is to be installed in an enclosed area, observe all confined space entry regulations and test the atmosphere for gas levels and dust content levels before using a cutting torch, welding equipment or electric hand tools. Using a torch, welding, grinding or drilling in an area with gas or dust may cause an explosion and/or fire resulting in serious injury or death.

! WARNING !

Before using a cutting torch, welders, or grinding equipment, cover the conveyor belt with a fire retardant/resistant cover. Make sure a water source/fire hose is readily available AND OPERATIONAL. Failure to do so can allow the belt to catch fire.

! WARNING !

Conveyor plows are heavy and may require two people to lift. Attempting to lift the plow without assistance could result in injuries or damage to the equipment.

Before Installing the BVP2-XXX-1RXC2

1. Inspect ALL shipping containers for damage and correct number of items (skids, pallets, cartons, boxes, etc.) being delivered. Report damage and/or shortages to delivery service immediately and fill out delivery service's claim form. Keep ALL damaged goods for examination. Benetech Inc is NOT responsible for damage occurring during transit.
2. All Benetech Inc. BVP2's are shipped from our facilities partially assembled. Care should be taken while disassembling the units to ensure no parts are lost or damaged as the equipment is moved to its desired location. Dispose of shipping containers in an approved manner.
3. If any items are missing, IMMEDIATELY contact BENETECH, INC. or an authorized representative.
4. Gather tools. Minimum tools required for installation are:
 - Tape measure/ String
 - Torch/Hole Saw
 - Level/Straight Edge
 - Welder/Drill
 - Open/Box End Wrenches
 - Socket Set
 - Marker/Soapstone (Welders chalk)
5. If using a cutting torch or welding, test atmosphere for gas level or dust content. Cover conveyor belt with fire retardant cover. Verify locations of fire extinguishers and operational water hoses prior to begin cutting/welding operations.



! WARNING !

Before installing equipment, turn off AND lock out/tag out all energy sources to the conveyor and conveyor accessories according to ANSI standards and local plant regulations. Failure to do so could result in serious injury or death.

If equipment will be installed in an enclosed area, the atmosphere in the structure/area must be tested for gas levels and dust content levels before using a cutting torch, welding equipment, grinding equipment or electric powered tools. Using a cutting torch, welding, drilling or grinding in an area with gas or dust may cause an explosion.

Installation Instructions

The *BVP2* is a single unit V-Plow designed to protect conveyor belts from damage caused by debris that could cycle between the pulley and belt surface. It protects by stopping objects that are on the return side of the belt by pushing them off and away from the moving pulley.

The *V-Plow* should be mounted as close to the tail pulley as possible in order to ensure optimum protection.

In some instances, the *V-Plow* may not fit in the position shown. Always locate it as close to the ideal positions as possible

Correct V-Plow positioning

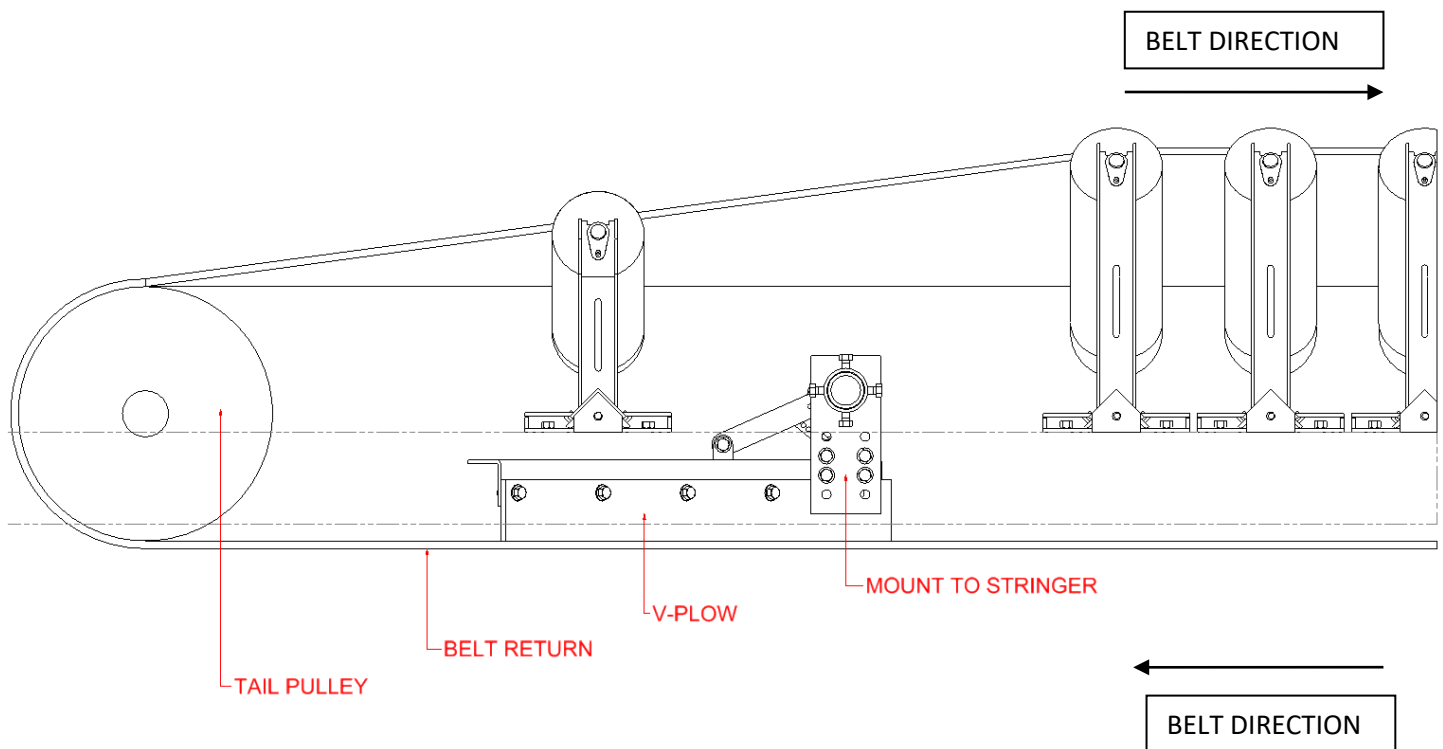

1. Locate the plow on the return side of the of the belt im a position similar to the one shown.

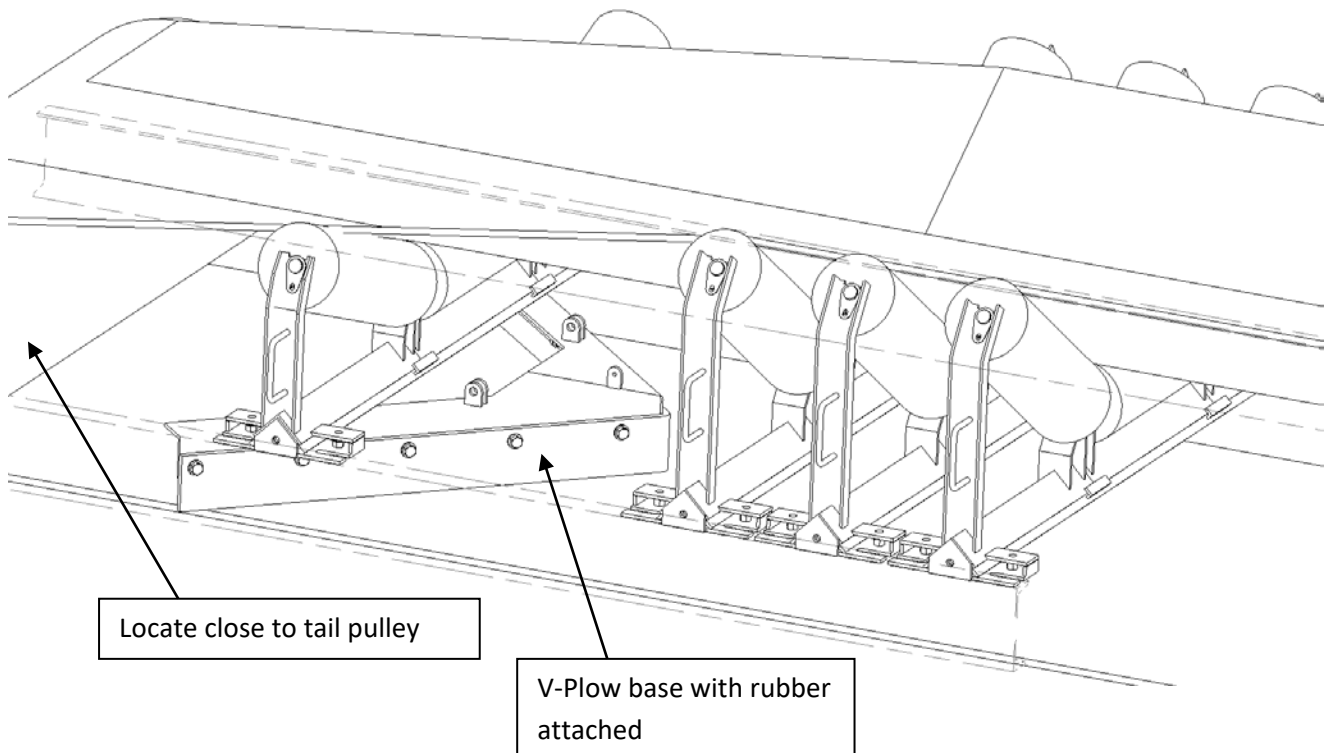
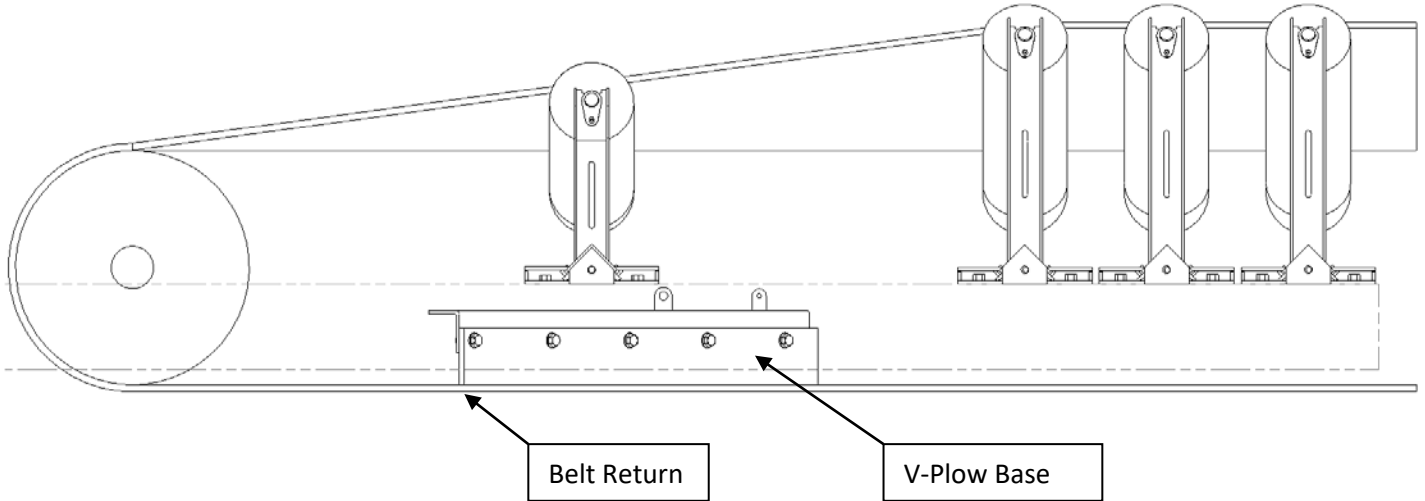

2. Attach V-Plow mounting pole.

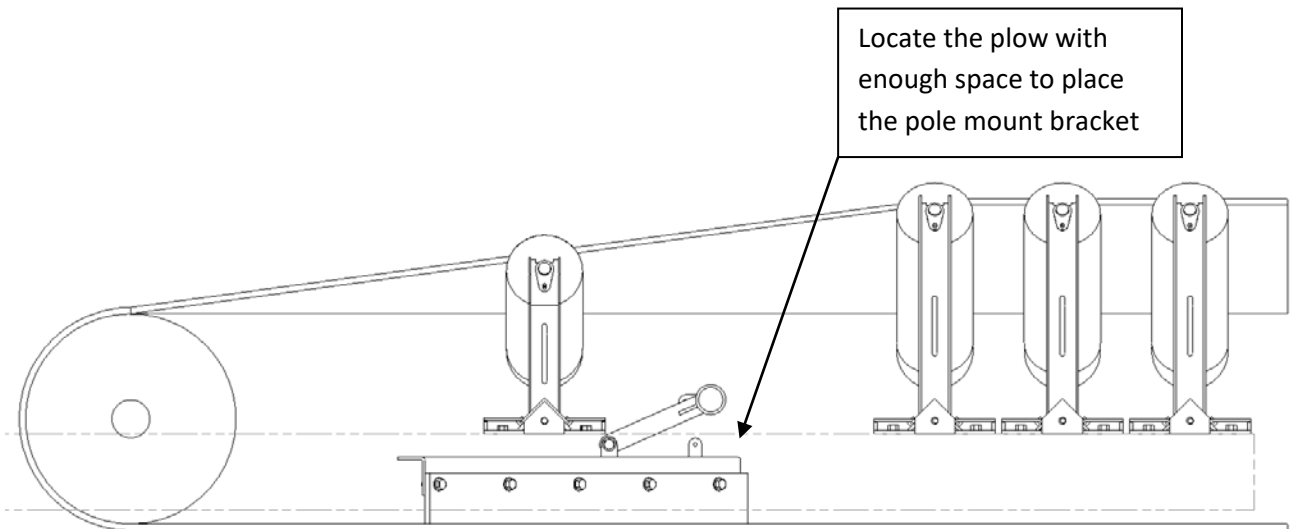
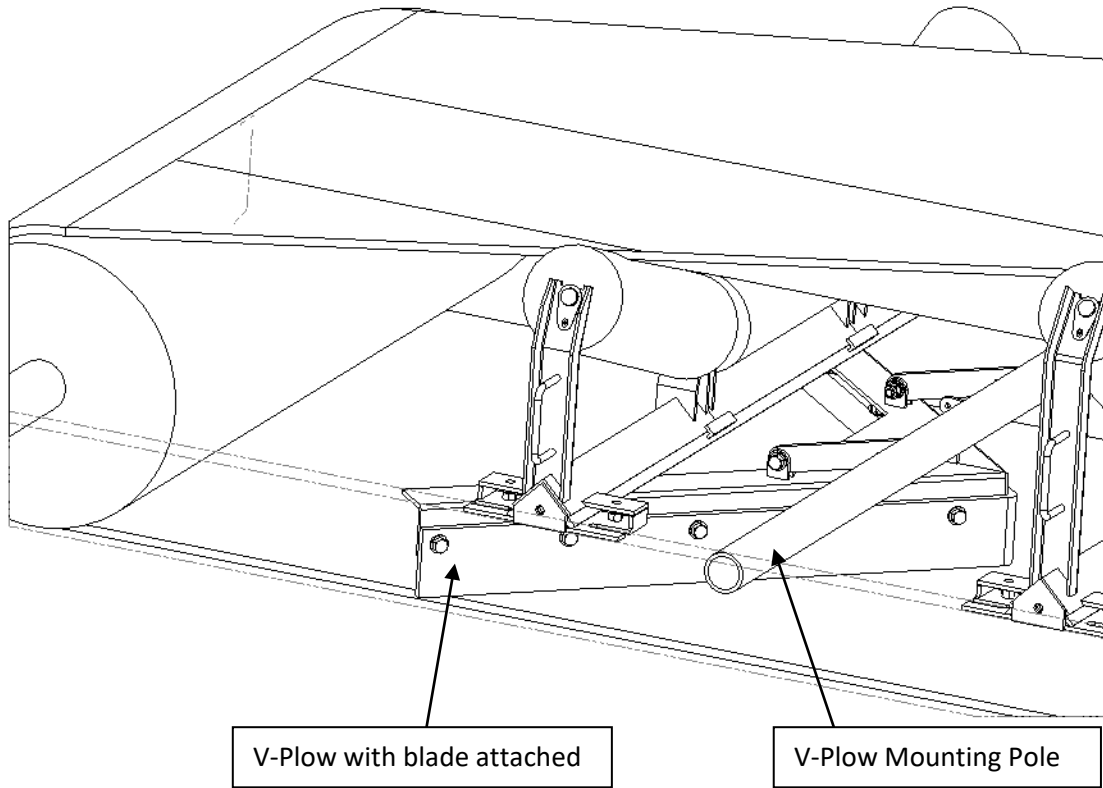

3. Place the mount bracket on the V-Plow pole, both sides of the pole.

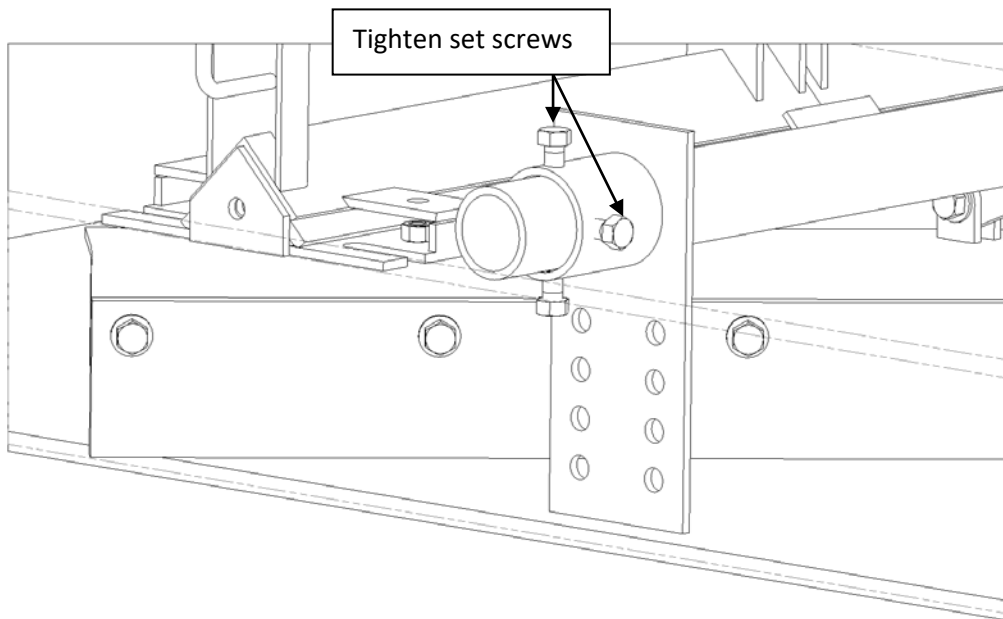
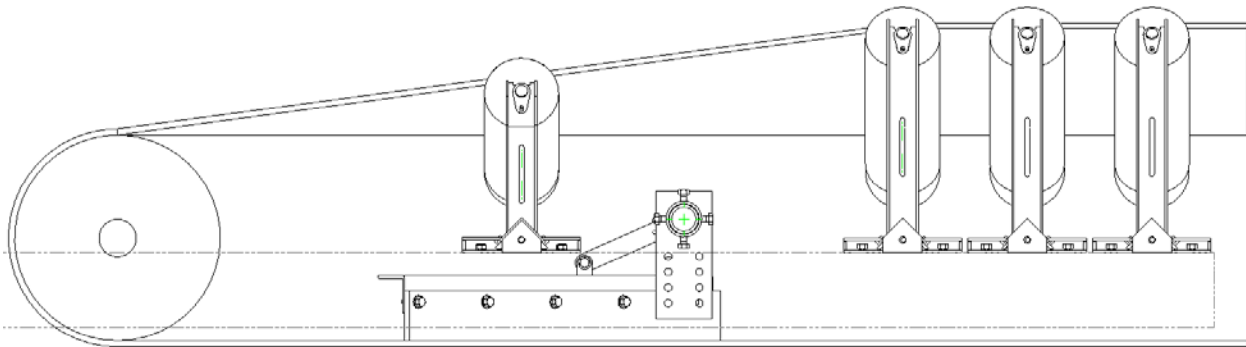

4. Attach adjustment arm

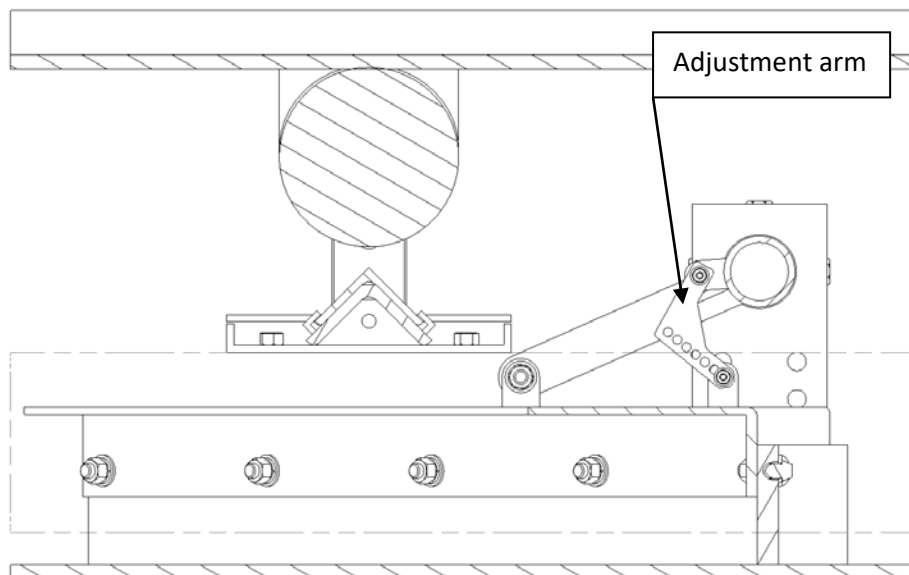

5. The "L" shaped adjustment arm contains multiple holes which allow the Plow to be adjusted a total height of 1.625"

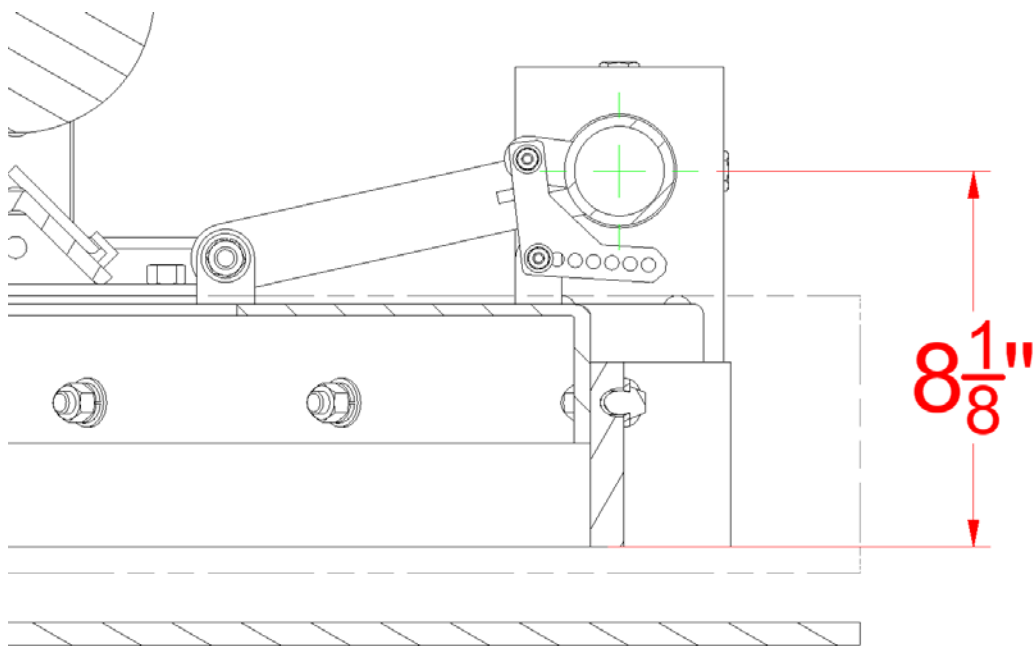
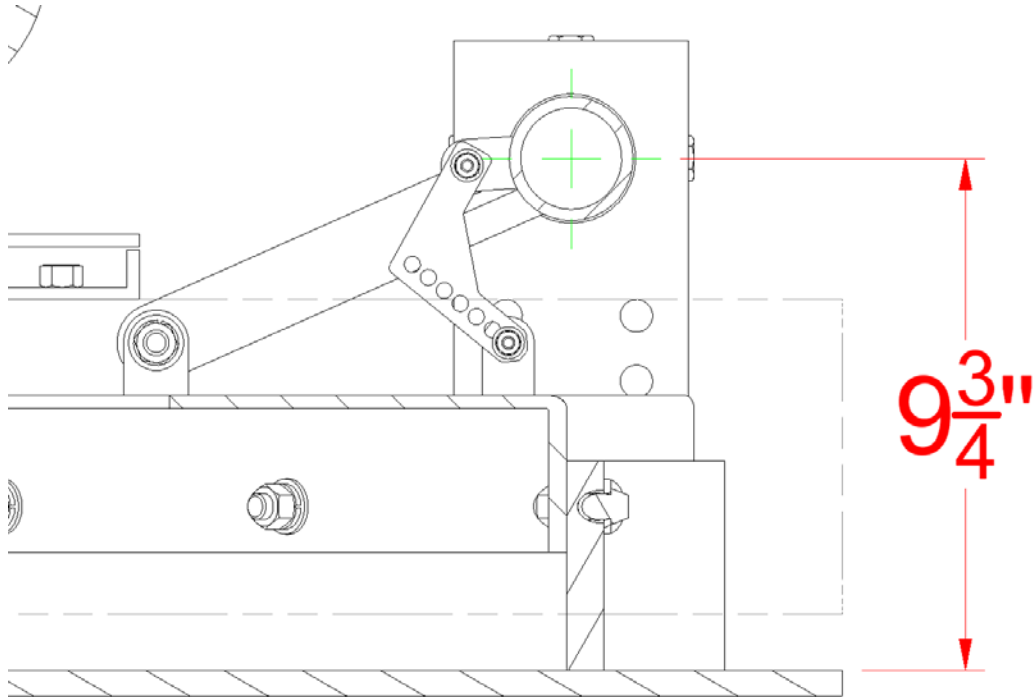

6. Set the Plow to the required height and attach the mounts to the stringer

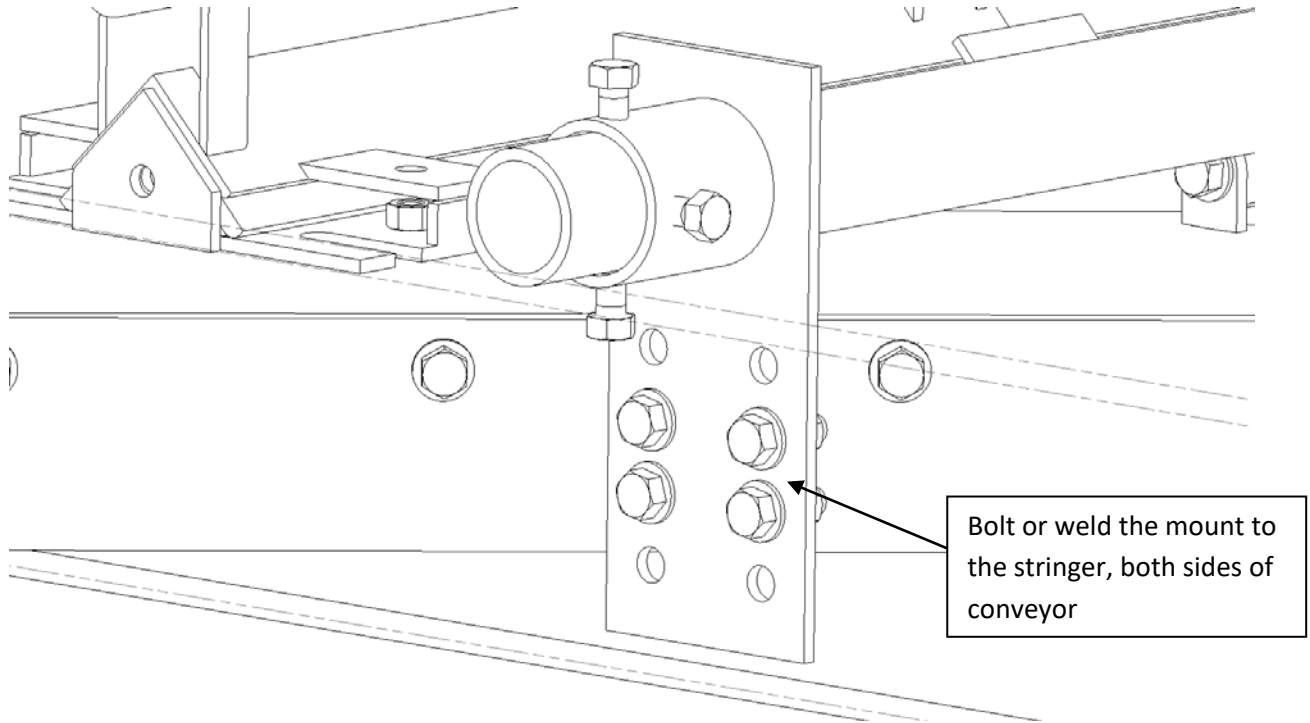

Correct V-Plow positioning shown

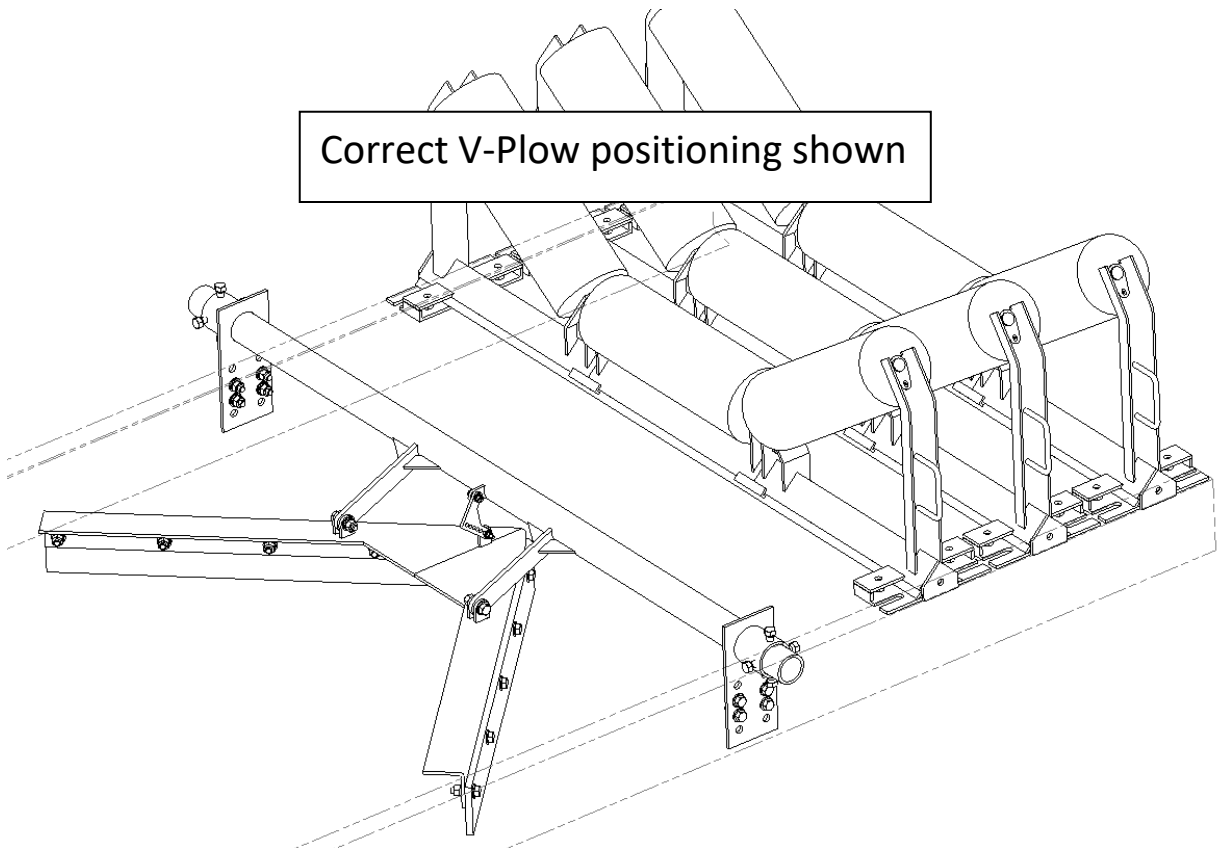

7. Attach and Secure safety cables as shown to a suitable anchor point. Welding the side cable connection tabs may be required.

Weld the connection tabs to the stringer, both sides of conveyor. Bolt safety cables as shown.

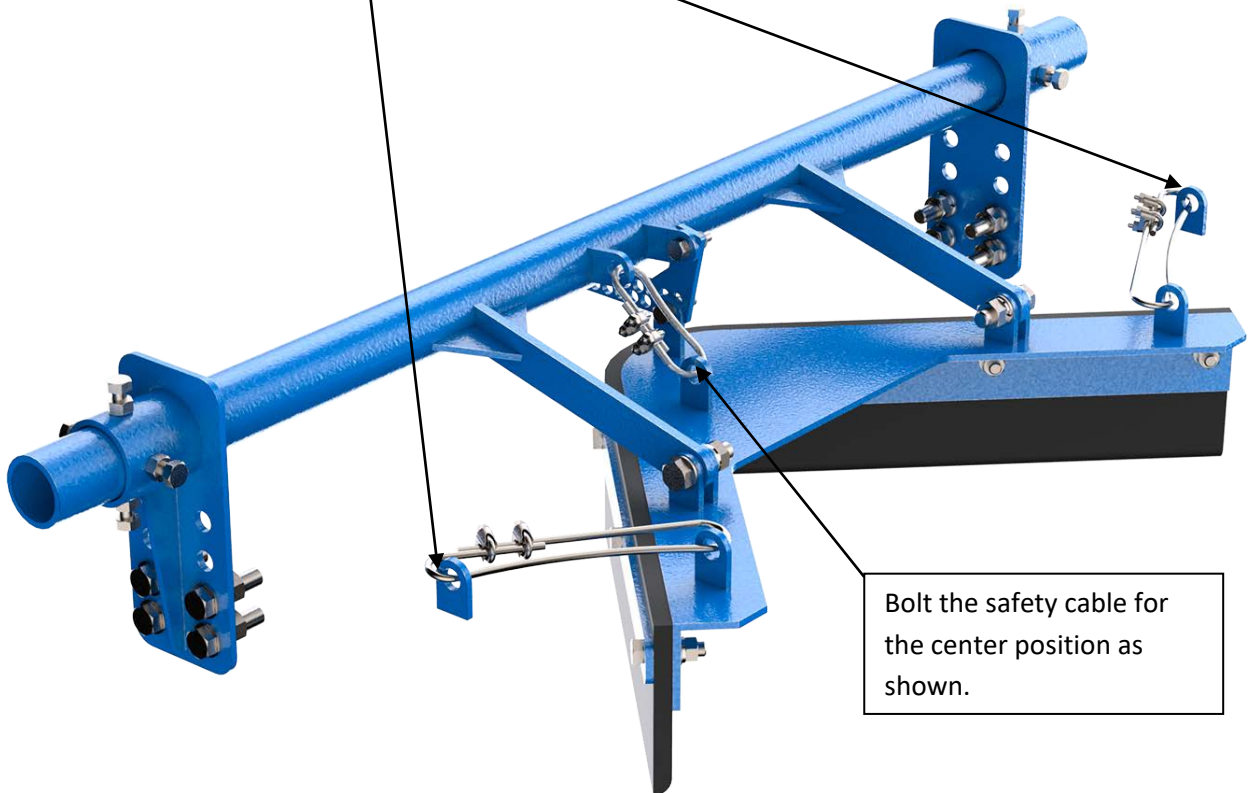

Bolt the safety cable for the center position as shown.